

RoHS 2.0

REV.	ECN NO.	DESCRIPTION	DATE	DESIGN
A1.	/.	重新核对图面	21.01.09	LiHui
		HD	22.06.07	LZR

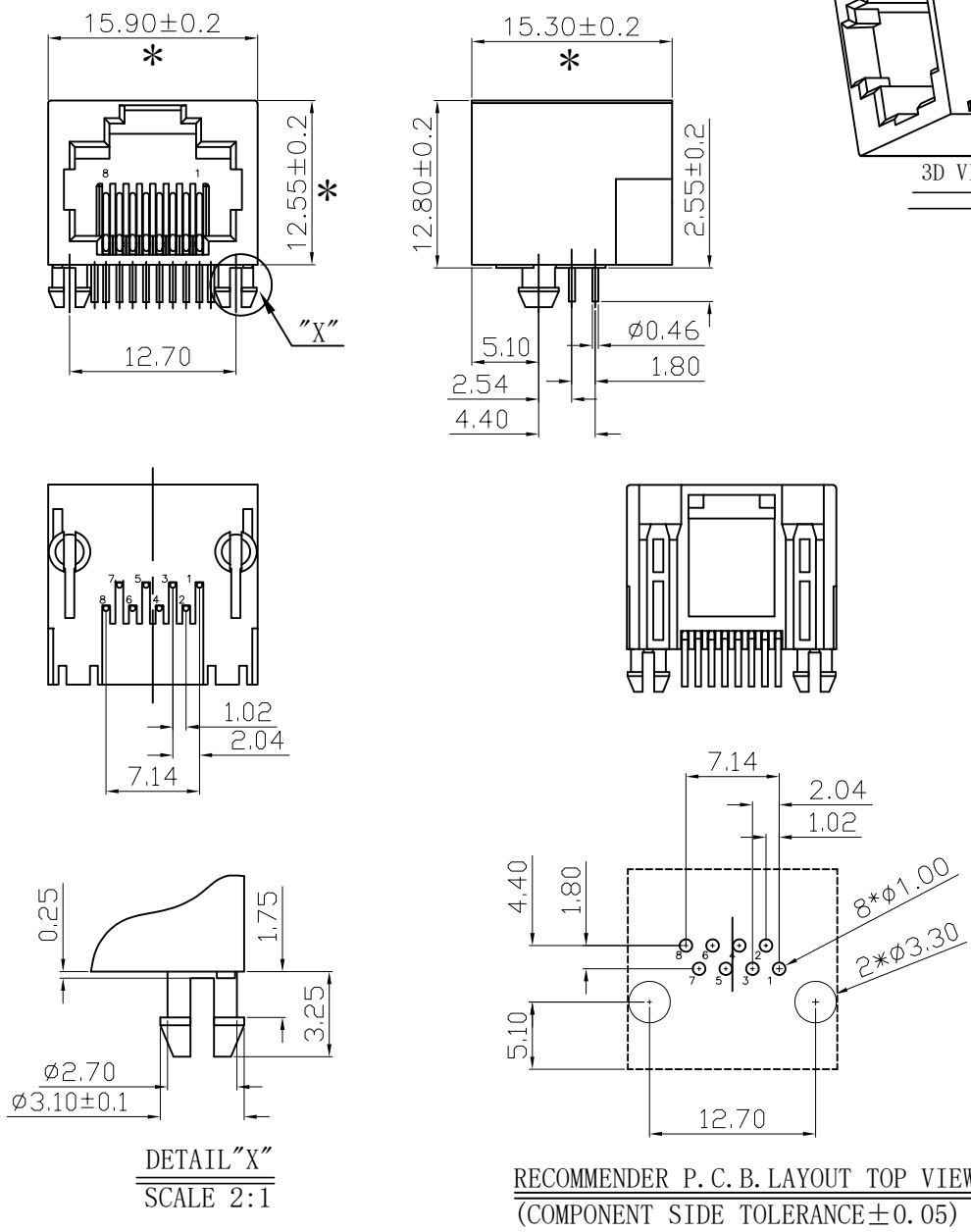

DETAIL "X"
SCALE 2:1

RECOMMENDER P. C. B. LAYOUT TOP VIEW
(COMPONENT SIDE TOLERANCE ± 0.05)

NOTES:

- MATERIAL:
 - HOUSING: PBT ,COLOR IS BLACK;
 - CONTACT: PHOSPHOR BRONZE, $\phi 0.46 \pm 0.02$ mm;
- FINISH: PLATED GOLD OVER NI;
- REINFORCED PCB THICKNESS: 1.60mm;
- ELECTRICAL:
 - VOLTAGE RATING: 125 VAC RMS;
 - CURRENT RATING: 1.5 AMP;
 - CONTACT RESISTANCE: 35MILLIOHMS MAX.;
 - WITHSTAND VOLTAGE: 1000 VAC RMS
50(60)Hz,1MIN.;
 - INSULATION RESISTANCE: 1000MEGOHMS MIN
@500V DC;
- MECHANICAL:
 - MATING/UNMATING FORCE: 30N MAX.;
 - RETENTION STRENGTH: 50N MIN.;
 - OPERATING LIFE: 750 CYCLES MIN.;
- SALT SPRAY TEST: 12H;(Excluding riveted bends)
- SOLDERABILITY: $245 \pm 5^\circ\text{C}, 5 \pm 0.5\text{S}$;
- RESISTANCE TO SOLDER: $260 \pm 5^\circ\text{C}, 10 \pm 1\text{S}$;
- ENVIRONMENTAL:
 - STORAGE TEMPERATURE RANGE: $-40^\circ\text{C} \sim +85^\circ\text{C}$;
 - OPERATION TEMPERATURE RANGE: $-25^\circ\text{C} \sim +70^\circ\text{C}$;
- MATES WITH: MODULAR PLUGS THAT CONFORM TO FCC REGULATION PART 68.500;
- THE MARK WITH "*" IS THE KEY INSPECTION DIMENSION FOR QC.

B	端子	磷铜	镀镍镀金 (G/F)	
A	基座	PBT	黑色	
序号	品名	材质	电镀/颜色	备注

深圳市虹成电子有限公司

UNLESS OTHERWISE, GENERAL TOLERANCE: X. xxx ± 0.10 X. xx ± 0.20 X. x ± 0.30	NAME:	RJ45全塑黑色		HCWLZ0054		
				DWG NO:		
ANGULAR: X. xx° $\pm 1^\circ$ X. x° $\pm 3^\circ$ X. ° $\pm 5^\circ$	THIRD ANGLE PROJECTION	UNIT:	SCALE:	SIZE:	SHEET:	REV.
		MM	1:1	A4	1/1	A1
	DRAWN:	CHECKED:		APPROVED:		