

REV.	ECN NO.	DESCRIPTION	DATE	DESIGN
A1.	/.	重新核对图面	20.12.28	LiHui
A2.	/.	重新核对图面	22.11.15	LZR

NOTES:

- MATERIAL:
  - HOUSING: PBT ,COLOR IS BLACK,UL94 V-0;
  - CONTACT: BRASS;
- FINISH: PLATED OVER NI&SN;
- RECINNEBDED PCB THICKNESS: 1.60mm MIN;
- ELECTRICAL:
  - VOLTAGE RATING: 30V DC ;
  - CURRENT RATING: 1A ;
  - CONTACT RESISTANCE: 35MILLIOHMS MAX.;
  - WITHSTAND VOLTAGE: 500 VAC RMS 50(60)Hz,1MIN.;
  - INSULATION RESISTANCE: 100MEGOHMS MIN @500V DC;
- MECHANICAL:
  - MATING FORCE: 25N MAX.;
  - UNMATING FORCE: 3~25N ;
  - OPERATING LIFE: 5000 CYCLES MIN.;
- SALT SPRAY TEST: 24H;
- SOLDERABILITY: 245±5°C,5±0.5S;
- RESISTANCE TO SOLDER: 260±5°C,10±1S;
- ENVIRONMENTAL:
  - STORAGE TEMPERATURE RANGE: -40°C~+85°C;
  - OPERATION TEMPERATURE RANGE: -25°C~+70°C;
- THE MARK WITH "\*" IS THE KEY INSPECTION DIMENSION FOR QC.

E	芯针	黄铜H62	镀镍锡	
D	PIN脚	黄铜H65	镀镍锡	
C	弹片	SUS304	镀镍锡	
B	后塞	PBT	黑色	
A	基座	PBT	黑色	
序号	品名	材质	电镀/颜色	备注

## 深圳市虹成电子有限公司

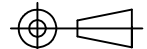
UNLESS OTHERWISE GENERAL TOLERANCE: X.xxx ±0.10 X.xx ±0.20 X.x ±0.30	NAME: DC005 (φ2.5铜芯窄脚)		P/N: HCDC-005-2.5-TQ		
	THIRD ANGLE PROJECTION 	UNIT: mm	SCALE: 1:1	SIZE: A4	SHEET: 1/1
ANGULAR: X.xx° ±1° X.x° ±3° X° ±5°	DRAWN:		CHECKED:		APPROVED

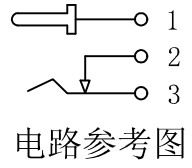
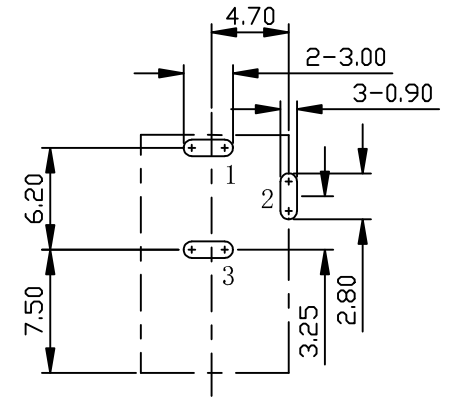
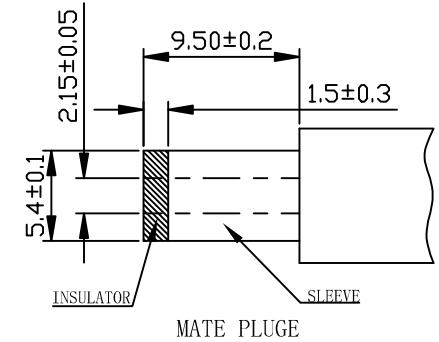
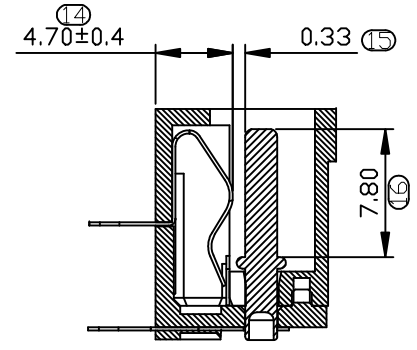
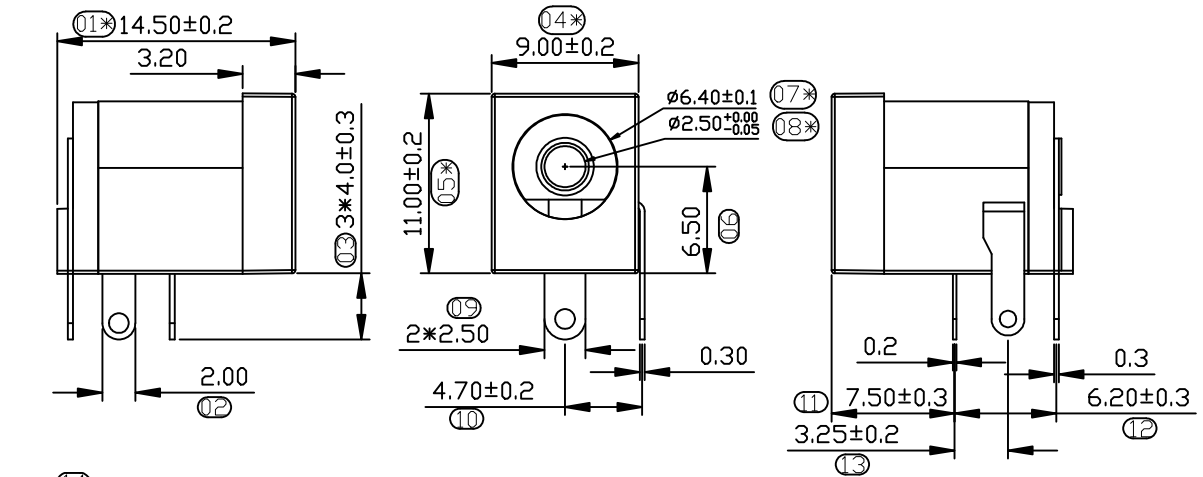

RECOMMENDED PCB LAYOUT  
TOP VIEW(TOL:±0.05)