

| REV | ECN NO. | DESCRIPTION | DATE | DESIGN |
|-----|---------|-------------|----------|--------|
| A1 | / | 重新核图面 | 20.12.28 | LiHui |
| A2 | / | 重新核图面 | 22.11.15 | LZR |

NOTES:

- MATERIAL:
 - HOUSING: PBT ,COLOR IS BLACK,UL94V-0;
 - CONTACT: COLD ROLLED IRON(SPCC);
- FINISH: PLATED OVER NI&SN;
- RECINNEBDED PCB THICKNESS: 1.60mm MIN;
- ELECTRICAL:
 - VOLTAGE RATING: 30V DC ;
 - CURRENT RATING: 1A ;
 - CONTACT RESISTANCE: 35MILLIOHMS MAX.;
 - WITHSTAND VOLTAGE: 500 VAC RMS 50(60)Hz,1MIN.;
 - INSULATION RESISTANCE: 100MEGOHMS MIN @500V DC;
- MECHANICAL:
 - MATING FORCE: 25N MAX.;
 - UNMATING FORCE: 3~25N ;
 - OPERATING LIFE: 5000 CYCLES MIN.;
- SALT SPRAY TEST: 12H
- SOLDERABILITY: 245±5°C,5±0.5S;
- RESISTANCE TO SOLDER: 260±5°C,10±1S;
- ENVIRONMENTAL:
 - STORAGE TEMPERATURE RANGE: -40°C~+85°C;
 - OPERATION TEMPERATURE RANGE: -25°C~+70°C;
- THE MARK WITH "*" IS THE KEY INSPECTION DIMENSION FOR QC.

| | | | | |
|----|------|--------|-------|----|
| E | 芯针 | SPCC | 镀镍锡 | |
| D | PIN脚 | SPCC | 镀镍锡 | |
| C | 弹片 | SUS304 | 镀镍锡 | |
| B | 后塞 | PBT | 黑色 | |
| A | 底座 | PBT | 黑色 | |
| 序号 | 品名 | 材质 | 电镀/颜色 | 备注 |

深圳市虹成电子有限公司

| UNLESS OTHERWISE SPECIFIED: | | NAME: | | P/N: | |
|-----------------------------|-------------|------------------------|----------|-----------------|-------|
| GENERAL TOLERANCE: | X.xxx ±0.10 | DC-005(φ2.0铁芯) | | HCDC-005-2.0-IQ | |
| | X.xx ±0.20 | THIRD ANGLE PROJECTION | UNIT: | SCALE: | SIZE: |
| | X.x ±0.30 | | mm | 1:1 | A4 |
| ANGULAR: | X.xx° ±1° | DRAWN: | CHECKED: | SHEET: | REV.: |
| | X.x° ±3° | | | 1/1 | A1 |
| | X° ±5° | | APPROVED | | |

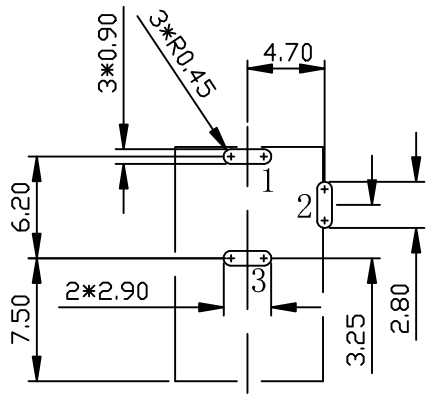
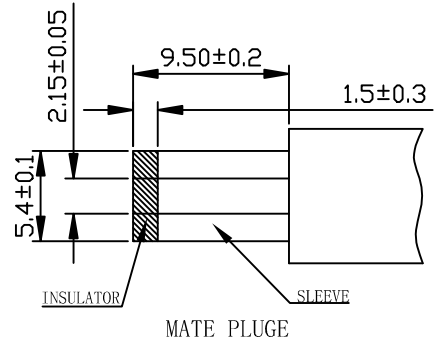
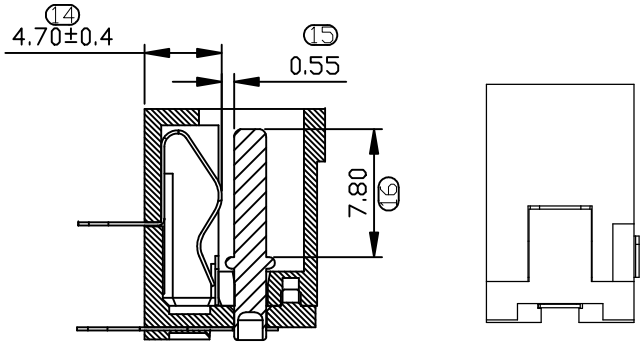
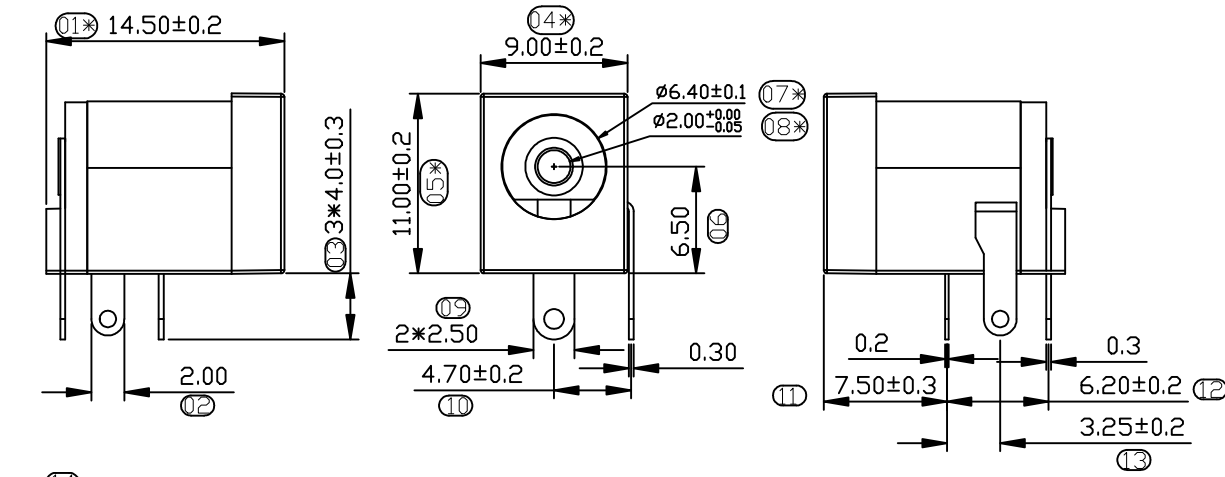

RECOMMENDED PCB LAYOUT
TOP VIEW(TOL:±0.05)

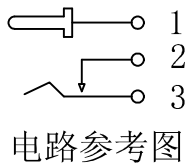

PART NO:
09.05.01.XXX

001:缺
002:缺