

RoHS 2.0

REV.	ECN NO.	DESCRIPTION	DATE	DESIGN
A0.	/.	正式版发行	21.12.20	Yang
A1.	/.	HD	22.09.19	LZR

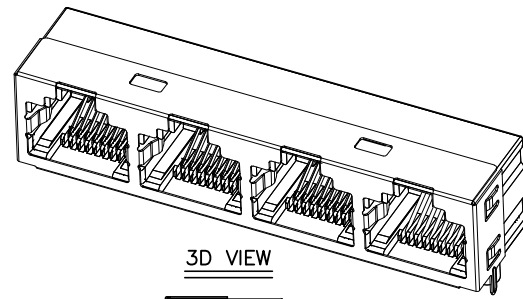

3D VIEW

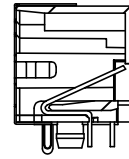

SECTION B-B

NOTES:

- MATERIAL:
 - HOUSING: PBT ,COLOR IS BLACK;
 - CONTACT: PHOSPHOR BRONZE, $\phi 0.46\pm 0.02\text{mm}$;
 - SHELL: COPPER ALLOY T=0.2mm;
- FINISH:
 - CONTACT: PLATED GOLD OVER NI;
 - SHELL: PLATED OVER NI;
- RECINNEBDED PCB THICKNESS: 1.0mm Min;
- ELECTRICAL:
 - VOLTAGE RATING: 125 VAC RMS;
 - CURRENT RATING: 1.5 AMP;
 - CONTACT RESISTANCE: 35MILLIOHMS MAX.;
 - WITHSTAND VOLTAGE: 1000 VAC RMS 50(60)Hz,1MIN.;
 - INSULATION RESISTANCE: 1000MEGOHMS MIN @500V DC;
- MECHANICAL:
 - MATING/UNMATING FORCE: 30N MAX.;
 - RETENTIION STRENGTH: 50N MIN.;
 - OPERATING LIFE: 750 CYCLES MIN.;
- SALT SPRAY TEST: 12H;
- SOLDERABILITY: $245\pm 5^{\circ}\text{C}, 5\pm 0.5\text{S}$;
- RESISTANCE TO SOLDER: $260\pm 5^{\circ}\text{C}, 10\pm 1\text{S}$;
- ENVIRONMENTAL:
 - STORAGE TEMPERATURE RANGE: $-40^{\circ}\text{C}\sim +85^{\circ}\text{C}$;
 - OPERATION TEMPERATURE RANGE: $-25^{\circ}\text{C}\sim +70^{\circ}\text{C}$;

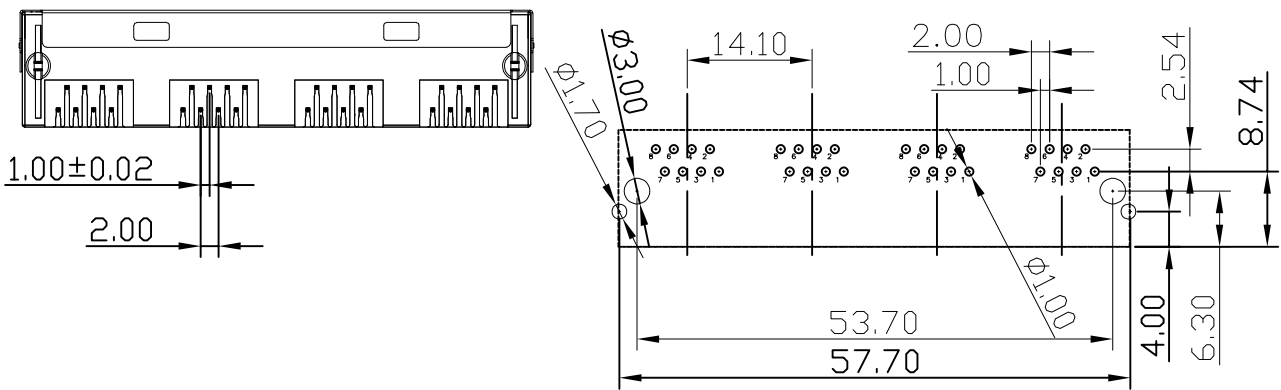
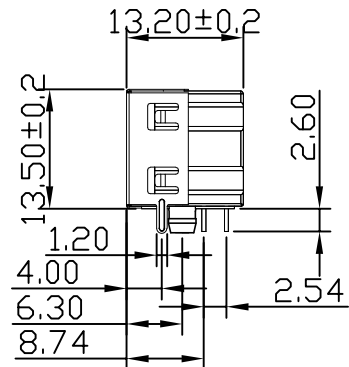
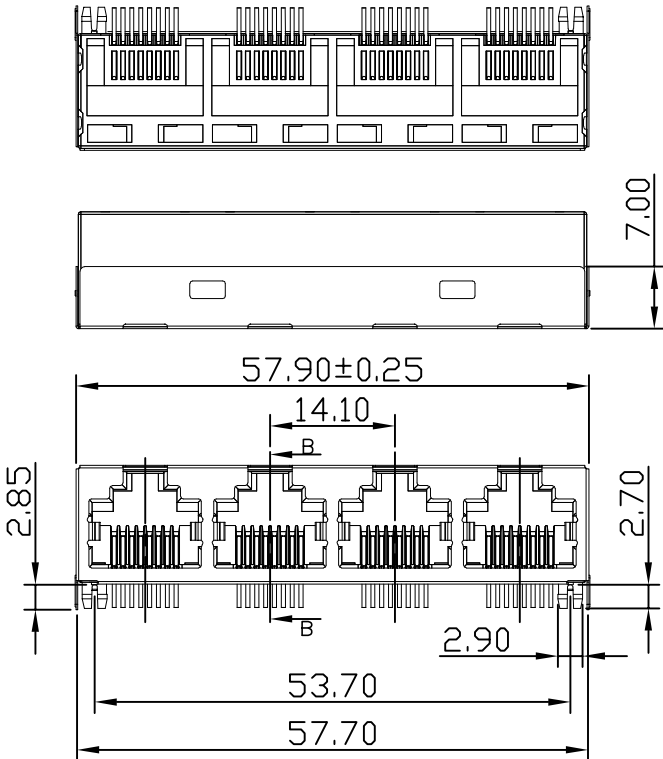

RECOMMENDED PCB LAYOUT
TOP VIEW(TOL:±0.05)

C	外壳	黄铜H65	镀镍	
B	端子	磷铜	焊料区镀锡 接触区镀金 G/F	
A	底座	PBT	黑色	
序号	品名	材质	电镀/颜色	备注

深圳市虹成电子有限公司

UNLESS OTHERWISE, GENERAL TOLERANCE: X. xxx ±0.10 X. xx ±0.20 X. x ±0.30 ANGULAR: X. xx° ±1° X. x° ±3° X. ° ±5°	NAME: RJ55-4口	P/N: HC-WK88-H132-1X4-55B DWG NO:			
	THIRD ANGLE PROJECTION	UNIT: MM	SCALE: 1:1	SIZE: A4	SHEET: 1/1
DRAWN: Yang	CHECKED: Mr Le	APPROVED: Mr Tang			