

RoHS 2.0

REV.	ECN NO.	DESCRIPTION	DATE	DESIGN
A0.	/.	正式版发行	21.12.20	Yang
		HD	22.04.21	LZR

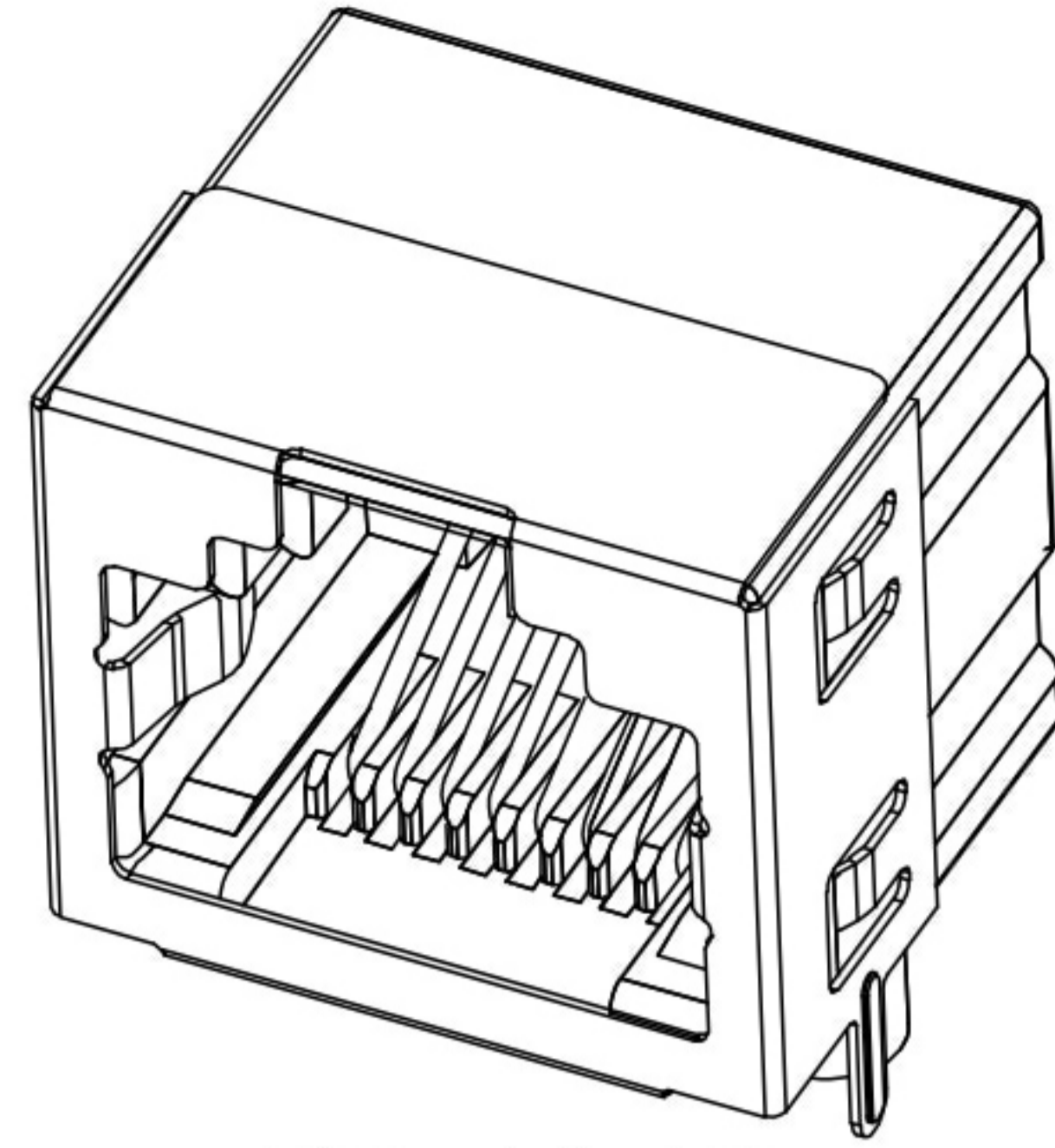

3D VIEW

- NOTES:
- MATERIAL:
 - HOUSING: PBT ,COLOR IS BLACK ;
 - CONTACT: PHOSPHOR BRONZE, $\phi 0.46 \pm 0.02$ mm;
 - SHELL: Stainless steel material
 - FINISH:
 - CONTACT: PLATED GOLD OVER NI;
 - SHELL: PLATED OVER NI;
 - RECOMMENDED PCB THICKNESS: 1.0mm Min;
 - ELECTRICAL:
 - VOLTAGE RATING: 125 VAC RMS;
 - CURRENT RATING: 1.5 AMP;
 - CONTACT RESISTANCE: 35MILLIOHMS MAX.;
 - WITHSTAND VOLTAGE: 1000 VAC RMS 50(60)Hz, 1MIN.;
 - INSULATION RESISTANCE: 1000MEGOHMS MIN @500V DC;
 - MECHANICAL:
 - MATING/UNMATING FORCE: 30N MAX.;
 - RETENTION STRENGTH: 50N MIN.;
 - OPERATING LIFE: 750 CYCLES MIN.;
 - SALT SPRAY TEST: 12H;
 - SOLDERABILITY: $245 \pm 5^{\circ}\text{C}, 5 \pm 0.5\text{S}$;
 - RESISTANCE TO SOLDER: $260 \pm 5^{\circ}\text{C}, 10 \pm 1\text{S}$;
 - ENVIRONMENTAL:
 - STORAGE TEMPERATURE RANGE: $-40^{\circ}\text{C} \sim +85^{\circ}\text{C}$;
 - OPERATION TEMPERATURE RANGE: $-25^{\circ}\text{C} \sim +70^{\circ}\text{C}$;

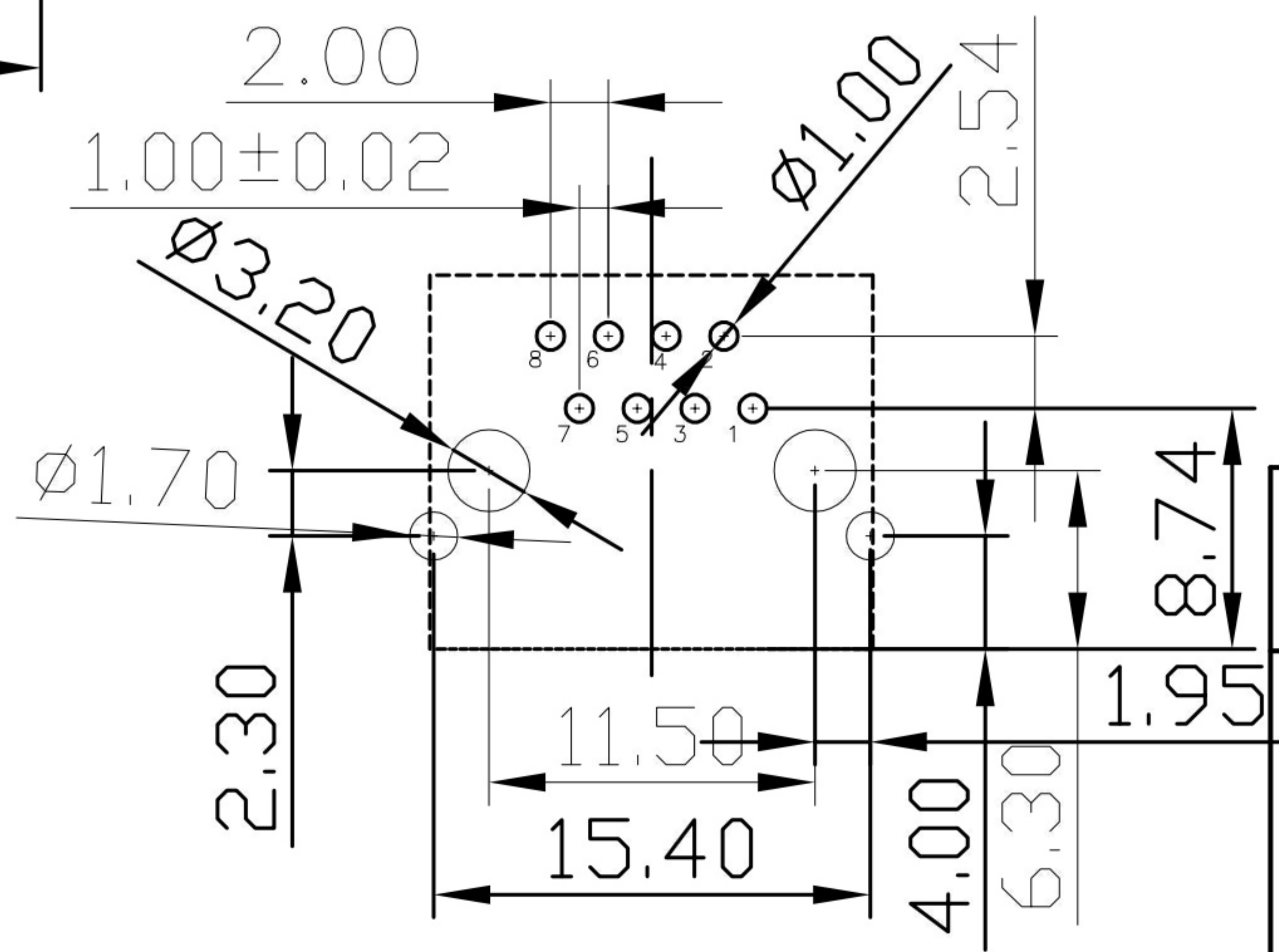
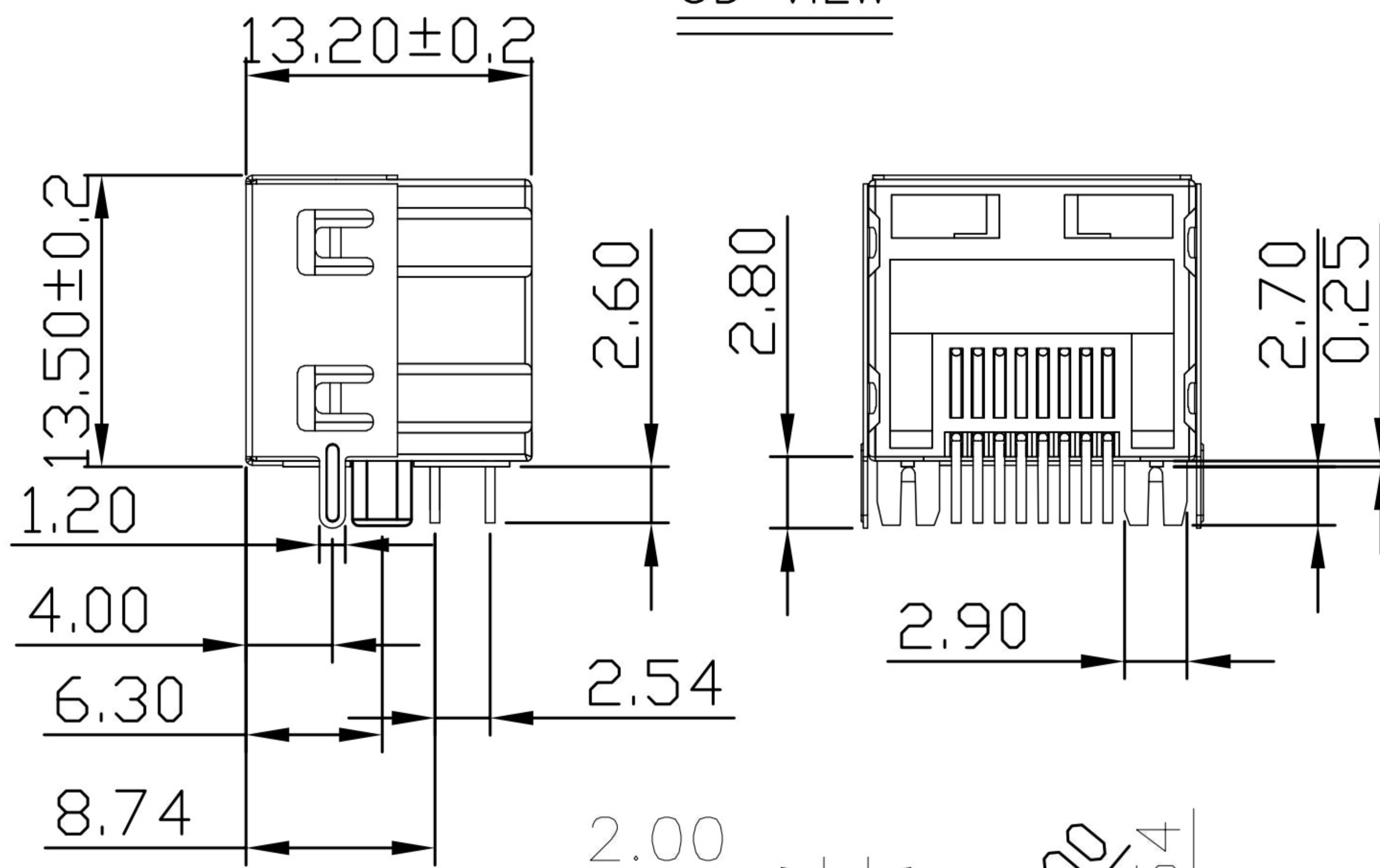
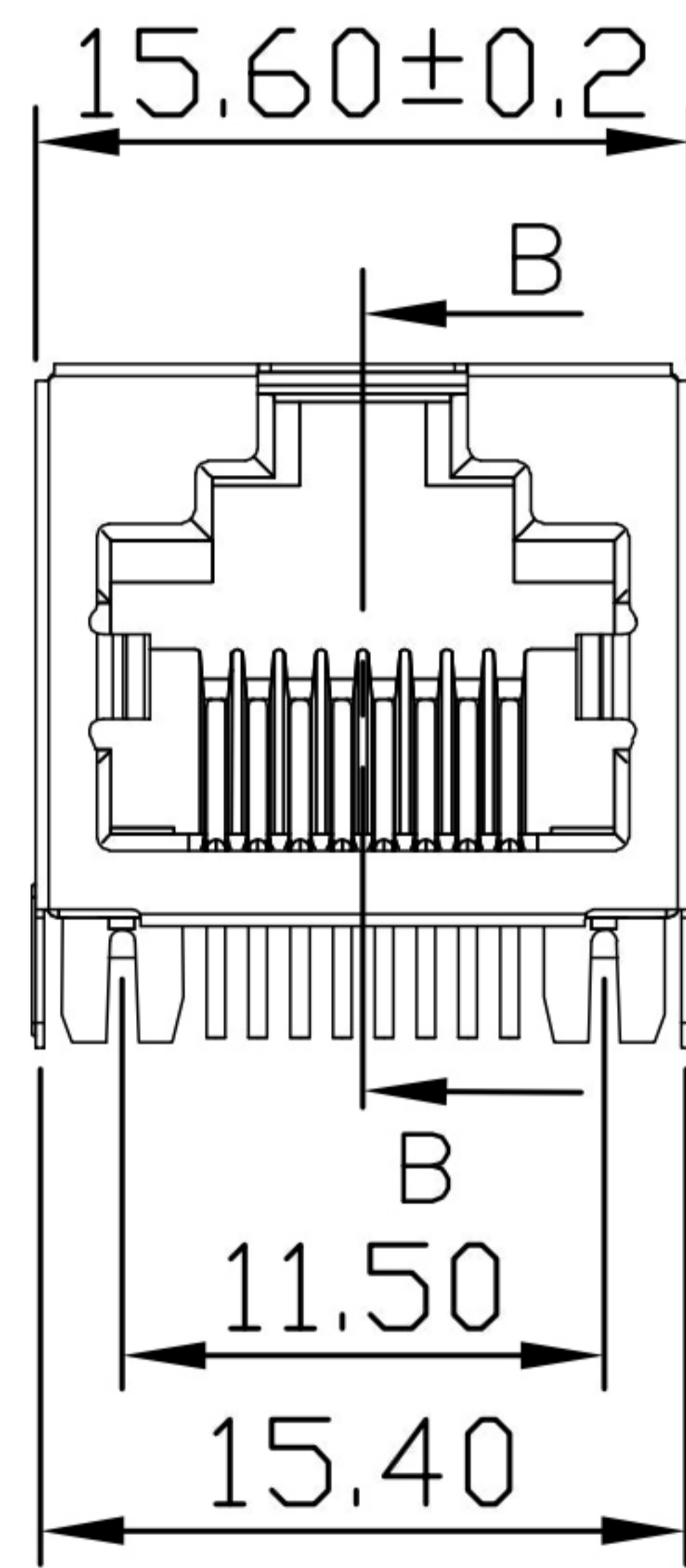
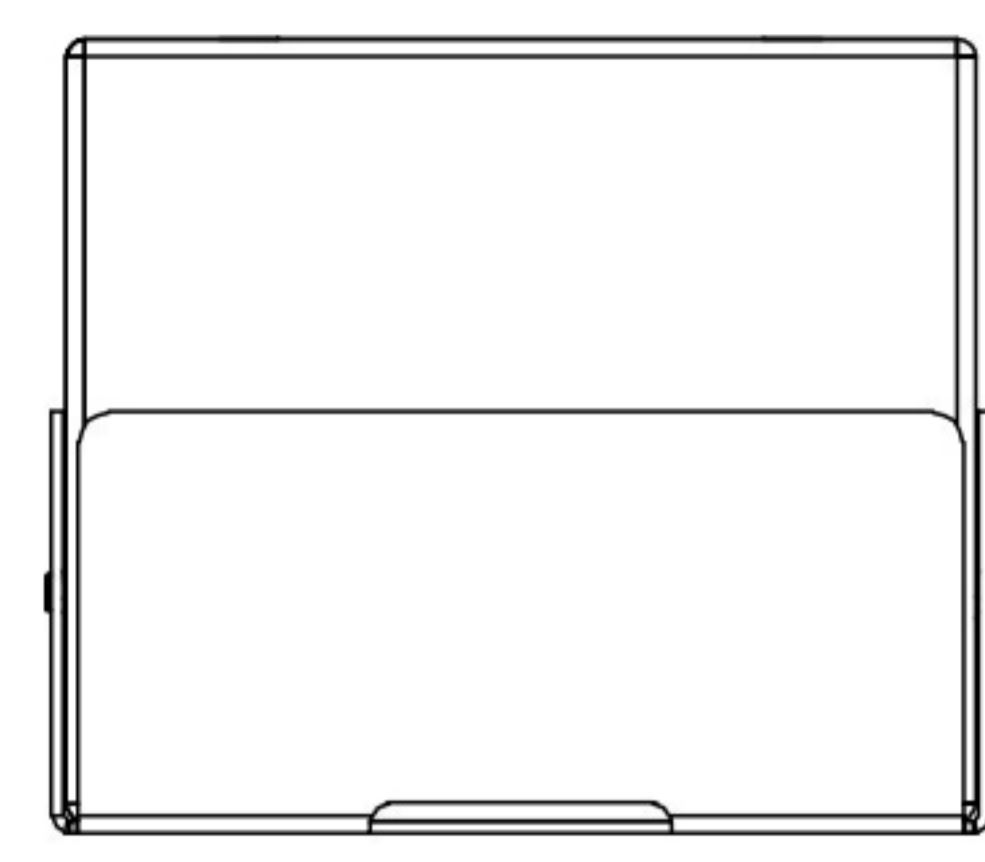

RECOMMENDED PCB LAYOUT
TOP VIEW(TOL:±0.05)

C	外壳	不锈钢	镀镍	
B	端子	磷铜	镀镍 镀金(G/F)	
A	基座	PBT	黑色	
序号	品名	材质	电镀/颜色	备注

深圳市虹成电子有限公司

UNLESS OTHERWISE, GENERAL TOLERANCE:		NAME: RJ55-单口半包		HC-WK88-H132-55B	
X. xxx	±0.10	THIRD ANGLE PROJECTION		UNIT:	SCALE:
X. xx	±0.20			MM	1:1
X. x	±0.30			SIZE:	SHEET:
ANGULAR:		DRAWN: Yang		CHECKED: Mr Le	APPROVED: Mr Tang
X. xx°	±1°				
X. x°	±3°				
X. °	±5°				