

RoHS 2.0

REV.	ECN NO.	DESCRIPTION	DATE	DESIGN
A0.	/.	正式版发行	21. 12. 20	Yang
A1.	/.	HD	22. 08. 25	LZR

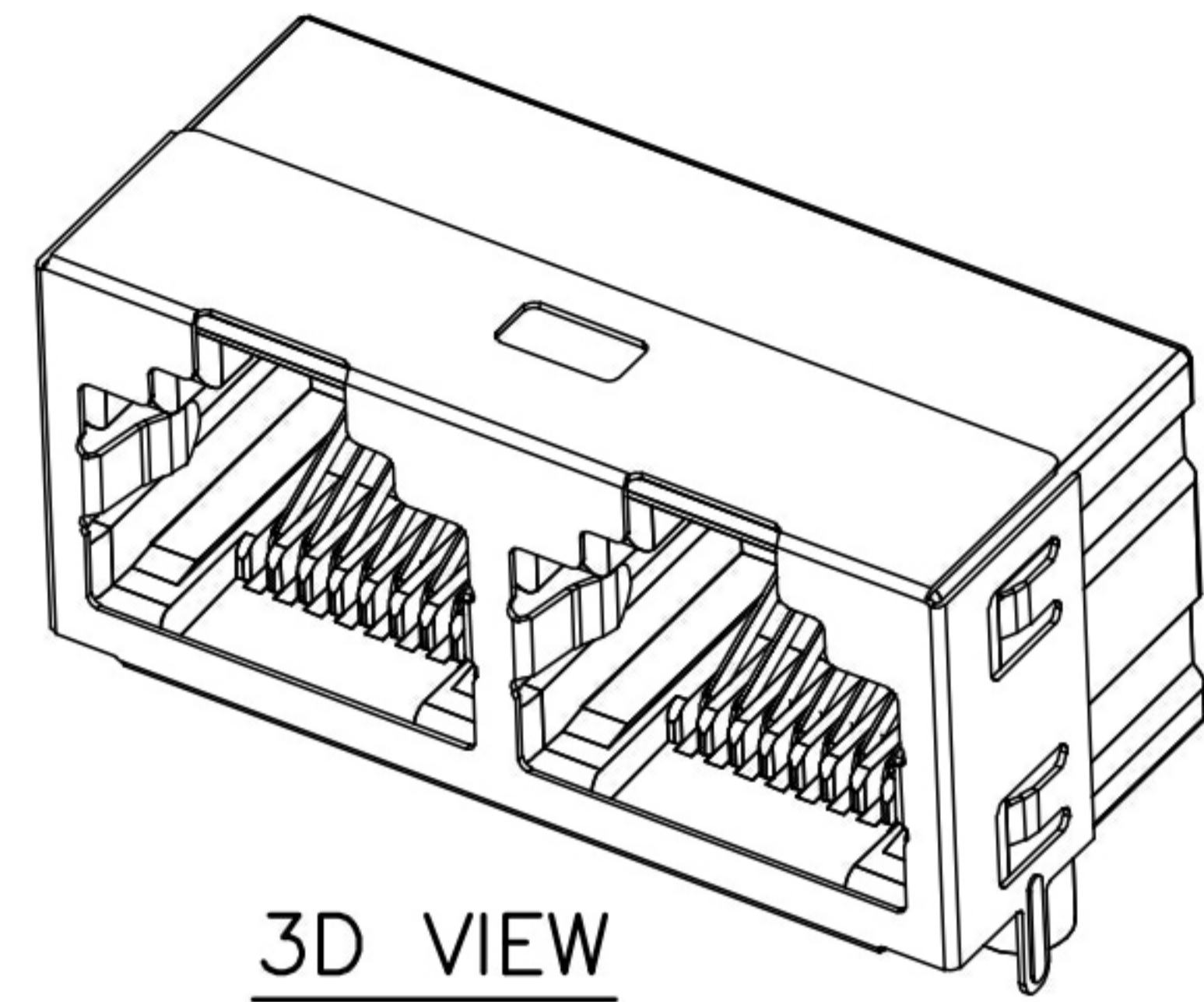

3D VIEW

NOTES:

- MATERIAL:
  - HOUSING: PBT ,COLOR IS BLACK;
  - CONTACT: PHOSPHOR BRONZE,  $\phi 0.46 \pm 0.02 \text{mm}$ ;
  - SHELL: Stainless steel material
- FINISH:
  - CONTACT: PLATED GOLD OVER NI;
  - SHELL: PLATED OVER NI;
- RECINNEBDED PCB THICKNESS: 1.0mm Min;
- ELECTRICAL:
  - VOLTAGE RATING: 125 VAC RMS;
  - CURRENT RATING: 1.5 AMP;
  - CONTACT RESISTANCE: 35MILLIOHMS MAX.;
  - WITHSTAND VOLTAGE: 1000 VAC RMS 50(60)Hz, 1MIN.;
  - INSULATION RESISTANCE: 1000MEGOHMS MIN @500V DC;
- MECHANICAL:
  - MATING/UNMATING FORCE: 30N MAX.;
  - RETENTION STRENGTH: 50N MIN.;
  - OPERATING LIFE: 750 CYCLES MIN.;
- SALT SPRAY TEST: 12H;
- SOLDERABILITY:  $245 \pm 5^\circ \text{C}$ ,  $5 \pm 0.5 \text{S}$ ;
- RESISTANCE TO SOLDER:  $260 \pm 5^\circ \text{C}$ ,  $10 \pm 1 \text{S}$ ;
- ENVIRONMENTAL:
  - STORAGE TEMPERATURE RANGE:  $-40^\circ \text{C} \sim +85^\circ \text{C}$ ;
  - OPERATION TEMPERATURE RANGE:  $-25^\circ \text{C} \sim +70^\circ \text{C}$ ;

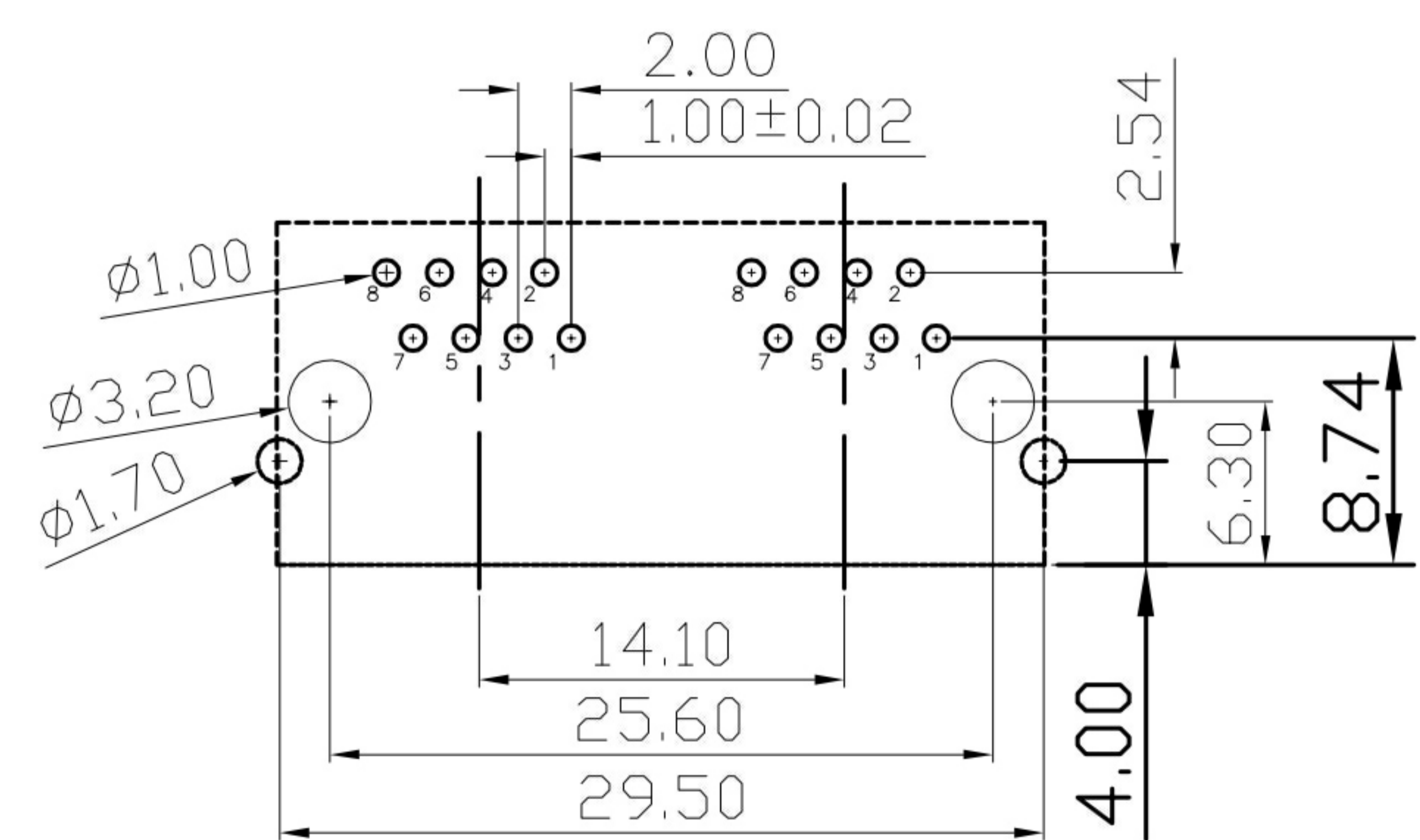
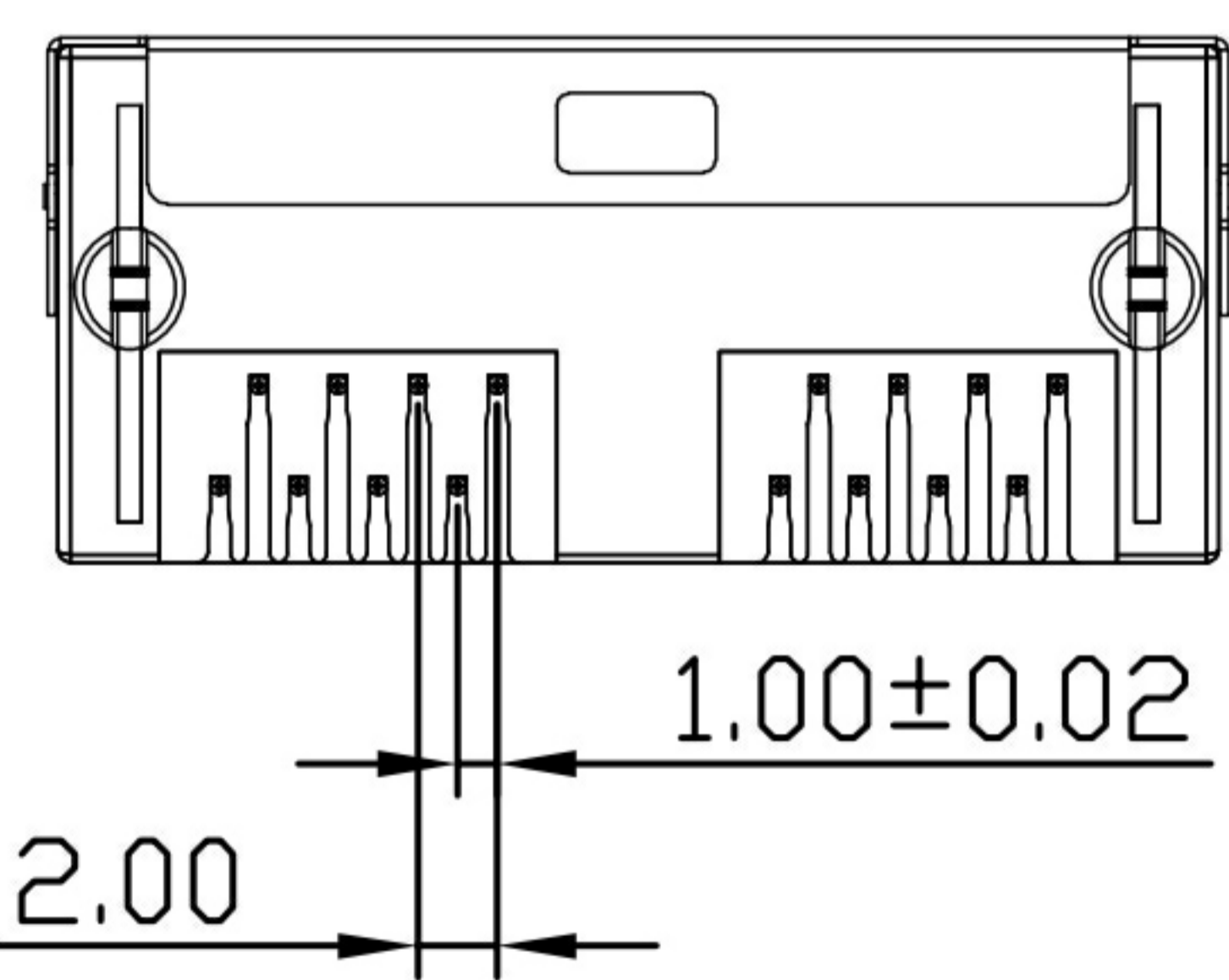
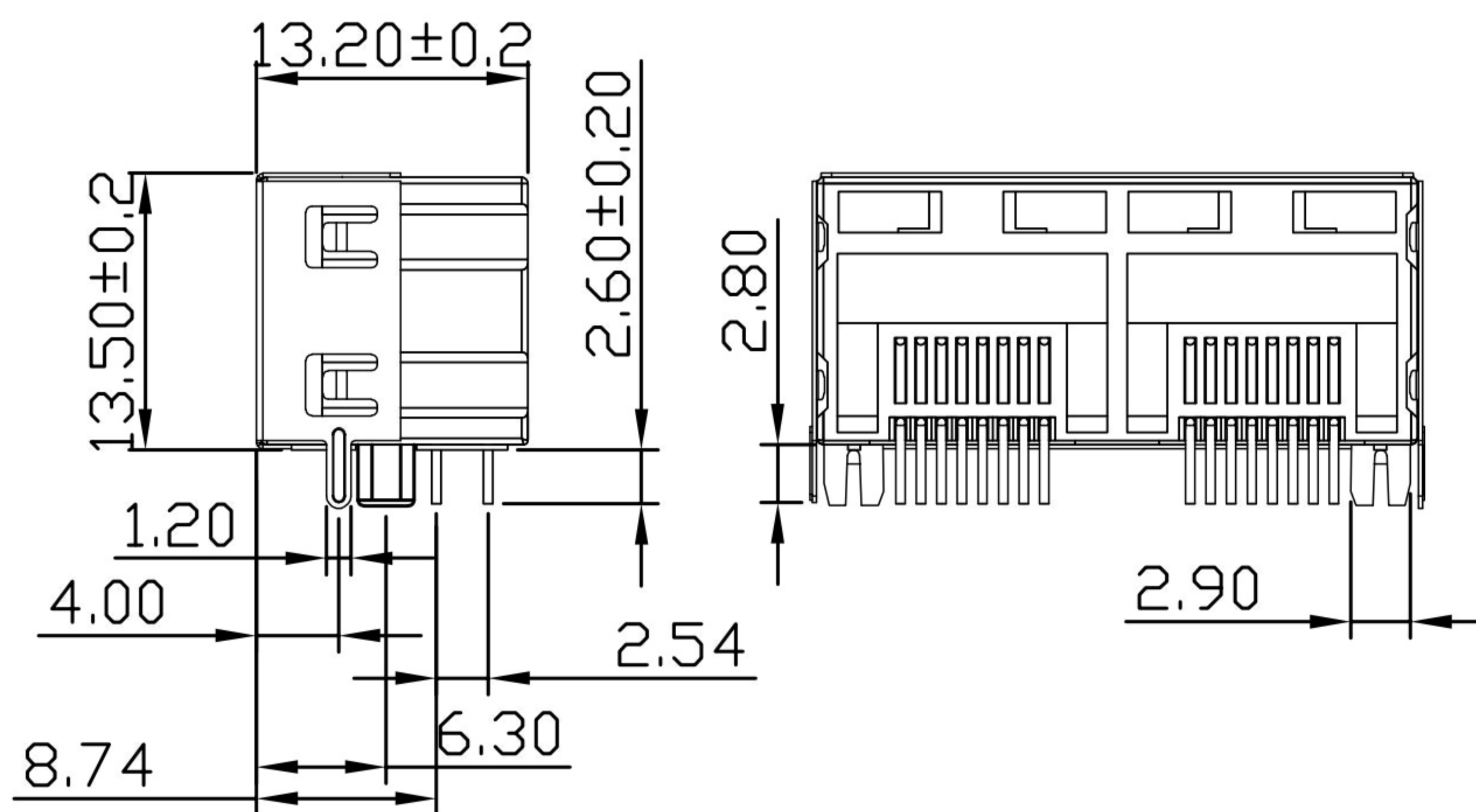
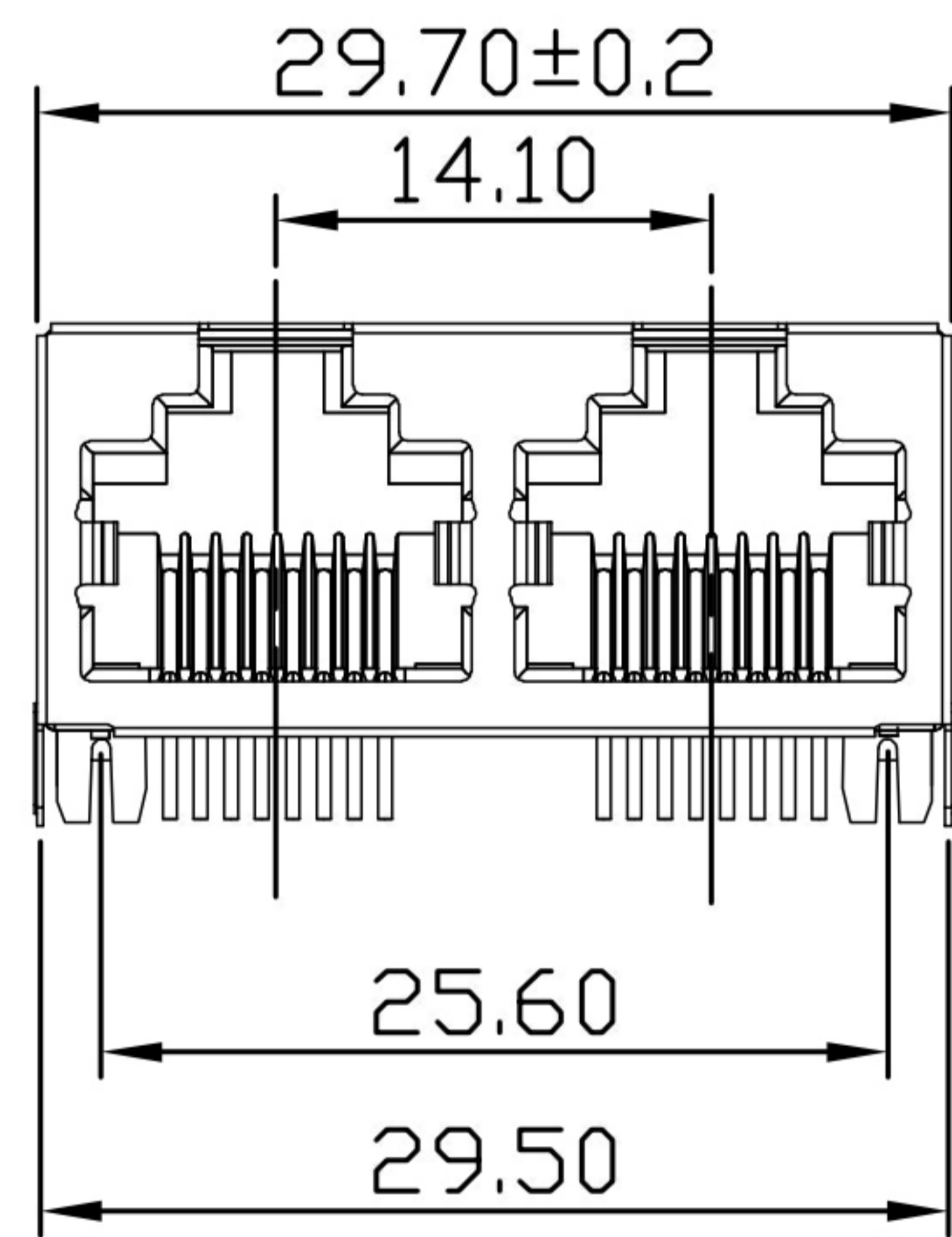
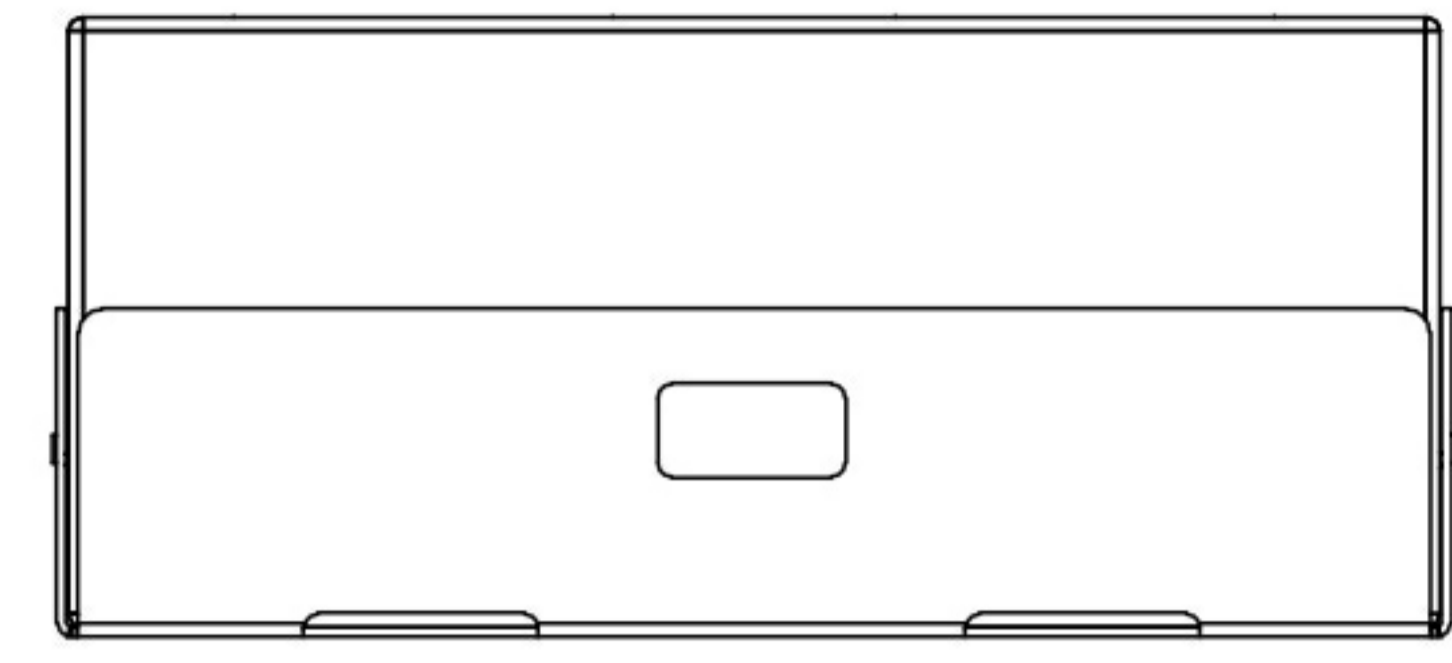

RECOMMENDED PCB LAYOUT  
TOP VIEW(TOL:±0.05)

C	外壳	不锈钢	镀镍	
B	端子	磷铜	镀镍 镀金(G/F)	
A	基座	PBT	黑色	
序号	品名	材质	电镀/颜色	备注

# 深圳市虹成电子有限公司

UNLESS OTHERWISE, GENERAL TOLERANCE: X. xxx ±0.10 X. xx ±0.20 X. x ±0.30 ANGULAR: X. xx° ±1° X. x° ±3° X. ° ±5°	NAME: RJ55-双口		HC-WK88-H132-1X2-55B		
	THIRD ANGLE PROJECTION 	UNIT: MM	SCALE: 1:1	SIZE: A4	SHEET: 1/1
DRAWN: Yang	CHECKED: Mr Le		APPROVED: Mr Tang		