

RoHS 2.0

REV.	ECN	NO.	DESCRIPTION	DATE	DESIGN
A1.	/.		重新核对图面	21.01.12	LiHui
A2.	/.		重新核对图面	22.11.15	LZR

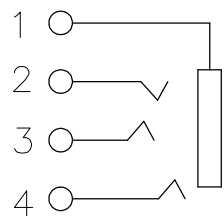

电气性能

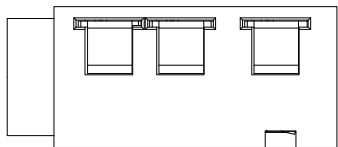
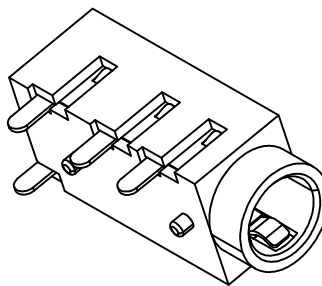

3D VIEW

NOTES:

- MATERIAL:
 - HOUSING: PPA.COLOR IS BLACK;
 - CONTACT: PHOSPHOR COPPER (C5191,T=0.2mm);
- FINISH:
 - TERMINAL:
 - CONTACT AREA: NI PLATED OVER ALL;
 - SOLDER AREA: SN PLATED OVER ALL;
- ELECTRICAL:
 - VOLTAGE RATING: 30 VAC RMS;
 - CURRENT RATING: 0.5 AMP;
 - CONTACT RESISTANCE: 30MILLIOHMS MAX.;
 - WITHSTAND VOLTAGE: 500 VAC RMS
50(60)Hz,1MIN.;
 - INSULATION RESISTANCE: 100MEGOHMS MIN
@500V DC;
- MECHANICAL:
 - MATING FORCE: 5~25N;
 - UNMATING FORCE: 5~25N;
 - OPERATING LIFE: 5000 CYCLES;
- ENVIRONMENTAL:
 - STORAGE TEMPERATURE RANGE: -40°C~+85°C;
 - OPERATION TEMPERATURE RANGE: -25°C~+70°C;
- SALT SPRAY TEST:8H(EXCLUDING RIVETED BENDS)

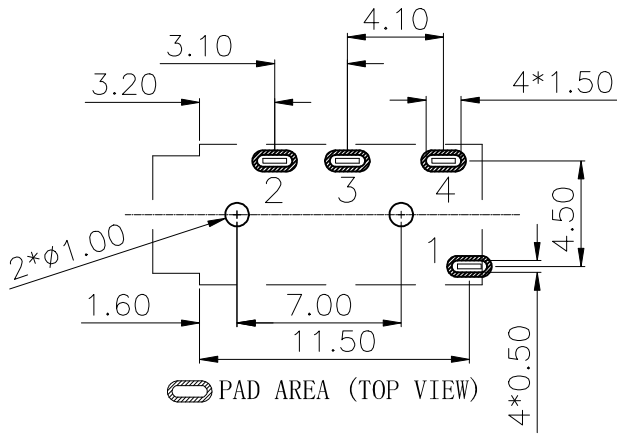
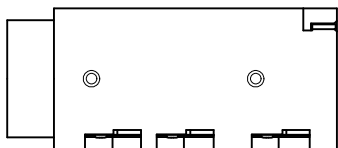
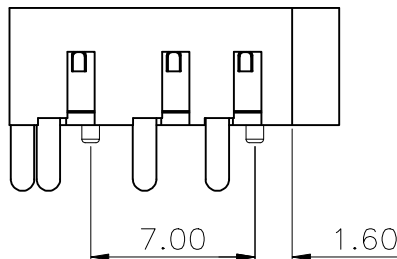
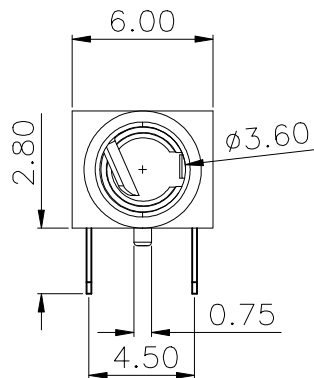
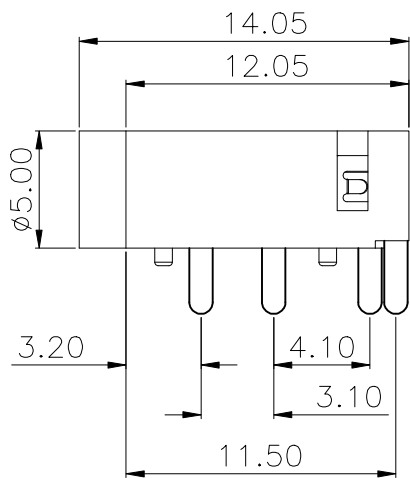

RECOMMEND PCB LAYOUT(±0.05)

B	端子	磷铜	镀镍 镀锡	
A	基座	LCP	黑色	
序号	品名	材质	电镀/颜色	备注

深圳市虹成电子有限公司

UNLESS GENERAL TOLERANCE: X.xxx ±0.10 X.xx ±0.20 X.x ±0.30	OTHERWISE:	NAME: 320D 红铜插件黑色	P/N: HC-PJ-320AB	
			DWG NO.:	
ANGULAR: X.xx° ±1° X.x° ±3° X° ±5°	THIRD ANGLE PROJECTION	UNIT: mm	SCALE: 1:1	SIZE: A4
		DRAWN:	CHECKED:	SHEET: 1/1
				REV.: A1
				APPROVED