

RoHS 2.0

REV.	ECN NO.	DESCRIPTION	DATE	DESIGN
A1.	/.	重新核对图面	21.01.03	LiHui
A2.	/.	HD	22.10.13	LZR

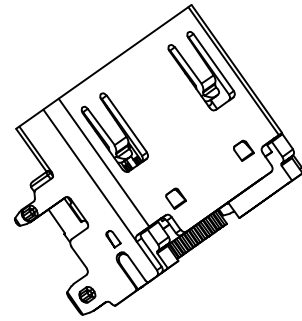

3D VIEW

NOTES:

- MATERIAL:
 - HOUSING: LCP, COLOR IS GRAY,HIGH TEMPERATURE PLASTIC;
 - CONTACT: BRASS (H65 T=0.20mm);
 - SHELL: COLD ROLLED IRON (SPCC,T=0.50mm);
- FINISH:
 - TERMINAL:
CONTACT AREA: GOLD PLATED G/Fu";
SOLDER AREA: PLATED OVER TIN;
 - SHELL: NI PLATED OVER ALL ;
- ELECTRICAL:
 - VOLTAGE RATING: 40 VAC RMS;
 - CURRENT RATING: 0.5 AMP;
 - CONTACT RESISTANCE: 30mΩ MAX.;
 - WITHSTAND VOLTAGE: 500 VAC RMS
50(60)Hz,1MIN.;
 - INSULATION RESISTANCE: 100MEGOHMS MIN
@500V DC;
- MECHANICAL:
 - MATING FORCE: 44.1N MAX.;
 - UNMATING FORCE: 9.8N MIN;
 - OPERATING LIFE: 10000 CYCLES MIN.;
- ENVIRONMENTAL:
 - STORAGE TEMPERATURE RANGE:-40°C~+85°C;
 - OPERATION TEMPERATURE RANGE:-25°C~+70°C;
- SALT SPRAY TEST:24H(Salt spray test 24hours for gold plated area and 8 hours for tin plated area)

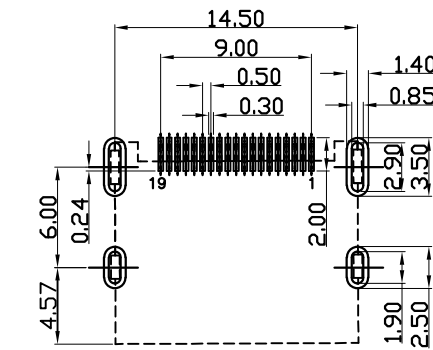
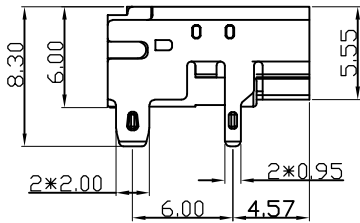
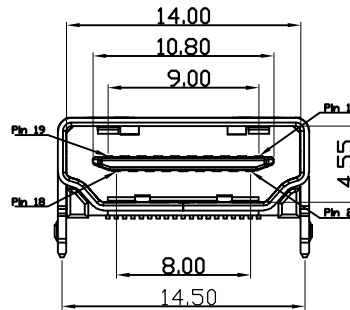
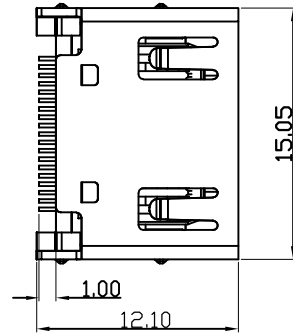

RECOMMEND PCB LAYOUT(±0.05)

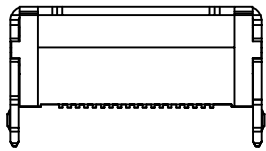
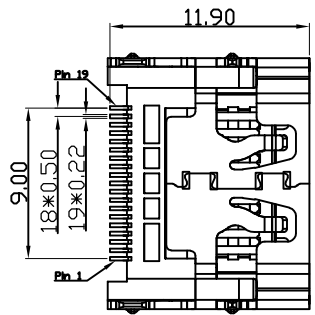

C	外壳	SPCC	镀锌	
B	端子	黄铜H65	焊料区镀锡 接触区镀金(1U)	
A	基座	LCP	灰色	
序号	品名	材质	电镀/颜色	备注

深圳市虹成电子有限公司

UNLESS OTHERWISE, GENERAL TOLERANCE: X.xxx ±0.10 X.xx ±0.20 X.x ±0.30	NAME: HDMI 铁小点镍	P/N: HC-HDMI0019T-11				
		DWG NO.:				
ANGULAR: X.xx' ±1' X.x' ±3' X.' ±5'	THIRD ANGLE PROJECTION	UNIT: mm	SCALE: 1:1	SIZE: A4	SHEET: 1/1	REV.:
	DRAWN:	CHECKED:		APPROVED		