

RoHS 2.0

REV.	ECN	NO.	DESCRIPTION	DATE	DESIGN
A1.	/.		新版发行	22.10.25	LZR

PIN NUMBER	SIGNAL NAME
PIN 1	Vbus
PIN 2	D-
PIN 3	D+
PIN 4	GND
PIN 5	StdA_SSRX-
PIN 6	StdA_SSRX+
PIN 7	GND_DRAIN
PIN 8	StdA_SSTX-
PIN 9	StdA_SSTX+
SHELL	GND

NOTES:

- MATERIAL:
  - HOUSING: LCP ,COLOR IS BLUE;
  - CONTACT: BRASS, (H65 T=0.20mm);
  - SHELL: COLD ROLLED IRON (SPCC,T=0.3mm);
- FINISH:
  - TERMINAL:
    - CONTACT AREA: GOLD PLATED G/Fu";
    - SOLDER AREA: PLATED OVER TIN;
  - SHELL: NI PLATED OVER ALL ;
- ELECTRICAL:
  - VOLTAGE RATING: 30 VAC RMS;
  - CURRENT RATING: 1.5 AMP;
  - CONTACT RESISTANCE: 30MILLIOHMS MAX.;
  - WITHSTAND VOLTAGE: 500 VAC RMS  
50(60)Hz,1MIN.;
  - INSULATION RESISTANCE: 100MEGOHMS MIN  
@500V DC;
- MECHANICAL:
  - MATING FORCE: 35N MAX.;
  - UNMATING FORCE: 5~35N;
  - OPERATING LIFE: 1500 CYCLES MIN.;
- ENVIRONMENTAL:
  - STORAGE TEMPERATURE RANGE: -40°C~+85°C;
  - OPERATION TEMPERATURE RANGE: -25°C~+70°C;
- SALT SPRAY TEST:24H(EXCLUDING RIVETED BENDS)

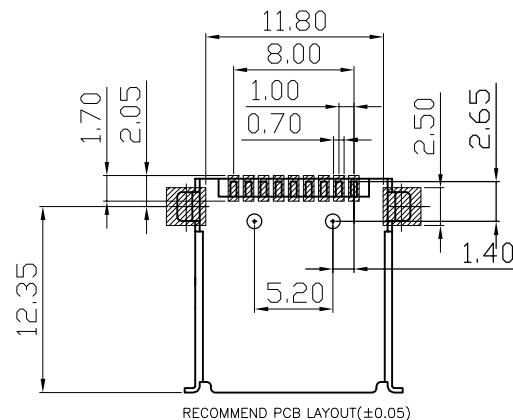
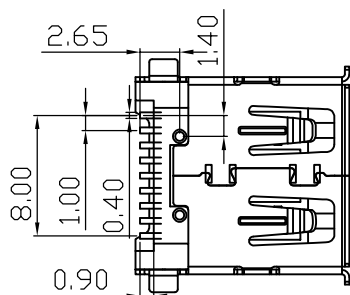
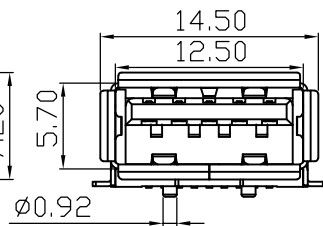
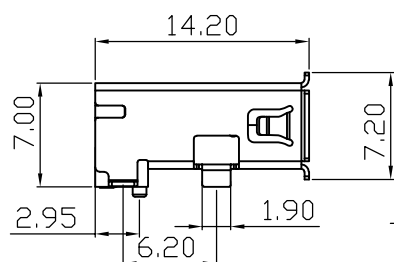
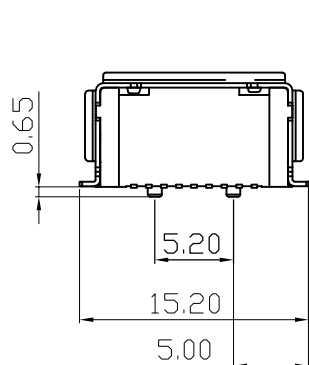
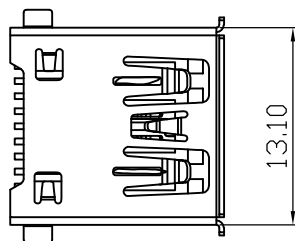
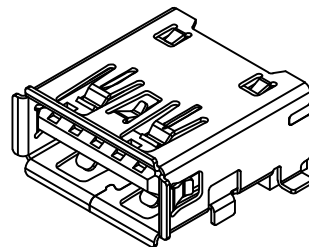

C	外壳	SPCC	镀镍	
B	端子	黄铜+65	焊料区镀锡 接触区镀金(1U)	
A	基座	LCP	蓝色	
序号	品名	材质	电镀/颜色	备注

## 深圳市虹成电子有限公司

UNLESS OTHERWISE, GENERAL TOLERANCE: X.xxx ±0.10 X.xx ±0.20 X.x ±0.30	NAME:	P/N: HC-USB3.0-L142-J			
	3.0 A母全贴卷边带定位柱 DWG NO.:				
ANGULAR: X.xx' ±1' X.x' ±3' X.' ±5'	THIRD ANGLE PROJECTION	UNIT:	SCALE:	SIZE:	SHEET:
		mm	1:1	A4	1/1
DRAWN:		CHECKED:		APPROVED	