

RoHS 2.0

PIN NUMBER	SIGNAL NAME
PIN 1	Vbus
PIN 2	D-
PIN 3	D+
PIN 4	GND
PIN 5	StdA_SSRX-
PIN 6	StdA_SSRX+
PIN 7	GND_DRAIN
PIN 8	StdA_SSTX-
PIN 9	StdA_SSTX+
SHELL	GND

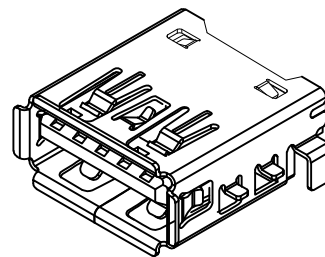

3D VIEW

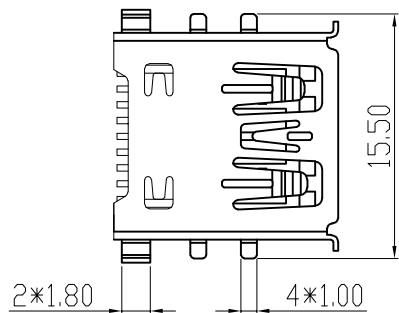
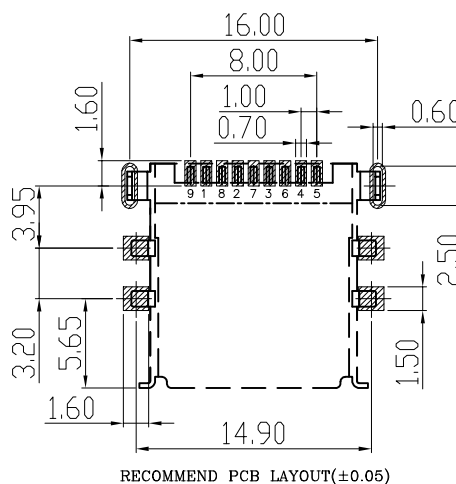
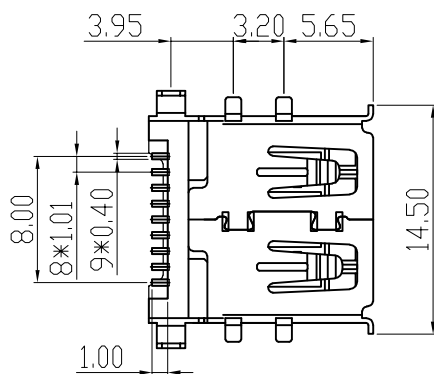
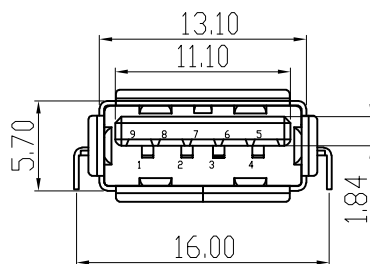
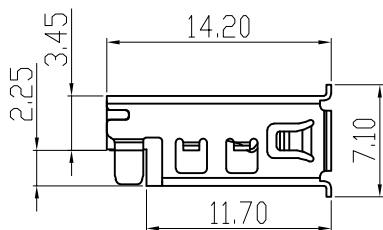
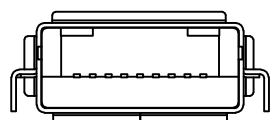

RECOMMEND PCB LAYOUT(±0.05)

REV.	ECN NO.	DESCRIPTION	DATE	DESIGN
A1.	/.	重新核对图面	21.01.04	LiHui
	/.	HD	22.07.16	LZR

NOTES:

- MATERIAL:
  - HOUSING: LCP ,COLOR IS BLUE,HIGH TEMPERATURE PLASTIC;
  - CONTACT: BRASS (H65 T=0.20mm);
  - SHELL: COLD ROLLED IRON (SPCC T=0.30mm);
- ELECTRICAL:
  - VOLTAGE RATING: 30V DC ;
  - CURRENT RATING: 1.5A ;
  - CONTACT RESISTANCE: 30MILLIOHMS MAX.;
  - WITHSTAND VOLTAGE: 100V AC RMS 50(60)Hz,1MIN.;
  - INSULATION RESISTANCE: 100MEGOHMS MIN @500V DC;
- MECHANICAL:
  - MATING FORCE: 35N MAX.;
  - UNMATING FORCE: 5~35N ;
  - OPERATING LIFE: 1500 CYCLES MIN.;
- PLATING:
  - TERMINAL:
    - NI PLATING OVER ALL,
    - Tin PLATING ON SOLDER AREA,
    - Au G/Fu" ON CONTACT AREA;
  - SHELL: NI PLATING OVER ALL;
- ENVIRONMENTAL:
  - STORAGE TEMPERATURE RANGE: -40°C~+85°C;
  - OPERATION TEMPERATURE RANGE: -25°C~+70°C;
  - SALT SPRAY TEST:24H(EXCLUDING RIVETED BENDS)

C	外壳	SPCC	镀镍	
B	端子	黄铜+65	焊料区镀锡 接触区镀金(1U)	
A	基座	LCP	蓝色	
序号	品名	材质	电镀/颜色	备注

# 深圳市虹成电子有限公司

UNLESS OTHERWISE GENERAL TOLERANCE: X.xxx ±0.10 X.xx ±0.20 X.x ±0.30	NAME:	P/N: HC-USB3. 0-C225-J				
	3.0 A母沉板直脚卷边B款		DWG NO.:			
ANGULAR: X.xx' ±1' X.x' ±3' X.' ±5'	THIRD ANGLE PROJECTION	UNIT:	SCALE:	SIZE:	SHEET:	REV.:
		mm	1:1	A4	1/1	A1
DRAWN:		CHECKED:		APPROVED		