

RoHS 2.0

PIN NUMBER	SIGNAL NAME
PIN 1	Vbus
PIN 2	D-
PIN 3	D+
PIN 4	GND
PIN 5	StdA_SSRX-
PIN 6	StdA_SSRX+
PIN 7	GND_DRAIN
PIN 8	StdA_SSTX-
PIN 9	StdA_SSTX+
SHELL	GND

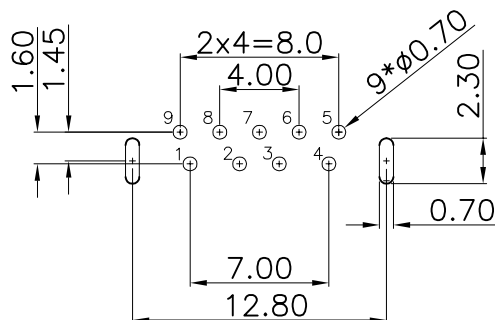
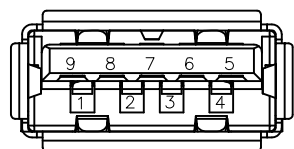
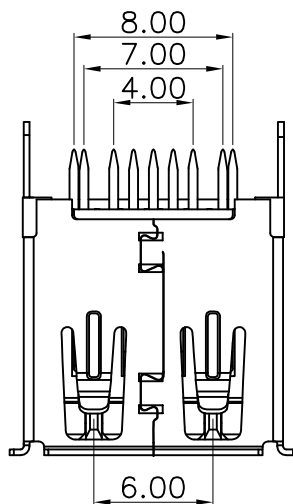
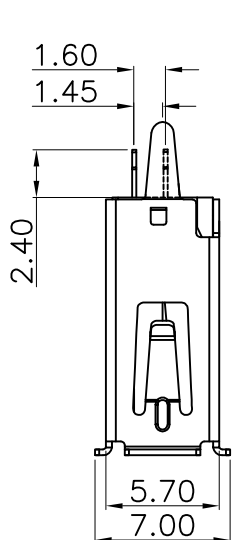
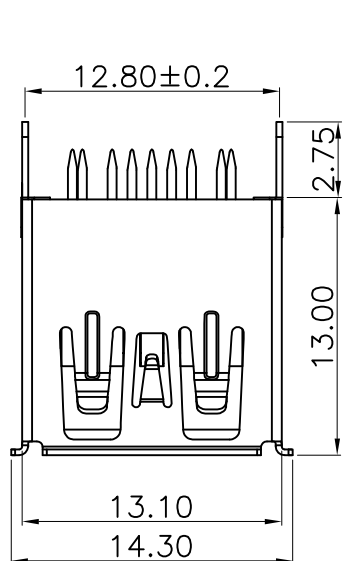
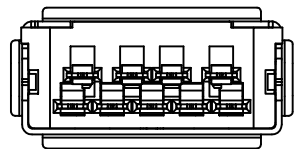
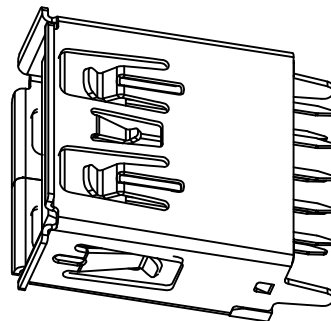

RECOMMENDER P.C.B.LAYOUT TOP VIEW
(COMPONENT SIDE TOLERANCE±0.05)

REV.	ECN NO.	DESCRIPTION	DATE	DESIGN
A0		新版发行	20/02/20	Yang
A1		重新核对图面	20/12/31	LiHui
		HD	22/07/08	LZR

NOTES:

- MATERIAL:
 - HOUSING: LCP ,COLOR IS BLUE,HIGH TEMPERATURE PLASTIC;
 - CONTACT: BRASS(H65 T=0.20&0.25mm);
 - SHELL: COLD ROLLED IRON(SPCC T=0.30mm);
- ELECTRICAL:
 - VOLTAGE RATING: 30V DC ;
 - CURRENT RATING: 1.5A ;
 - CONTACT RESISTANCE: 30MILLIOHMS MAX.;
 - WITHSTAND VOLTAGE: 100V AC RMS 50(60)Hz,1MIN.;
 - INSULATION RESISTANCE: 100MEGOHMS MIN @500V DC;
- MECHANICAL:
 - MATING FORCE: 35N MAX.;
 - UNMATING FORCE: 5~35N ;
 - OPERATING LIFE: 1500 CYCLES MIN.;
- PLATING:
 - TERMINAL:
 - NI PLATING OVER ALL,
 - Tin PLATING ON SOLDER AREA,
 - Au 1U" ON CONTACT AREA;
 - SHELL: NI PLATING OVER ALL;
- ENVIRONMENTAL:
 - STORAGE TEMPERATURE RANGE: -40°C~+85°C;
 - OPERATION TEMPERATURE RANGE: -25°C~+70°C;
- SALT SPRAY TEST:24H(EXCLUDING RIVETED BENDS)

C	外壳	SPCC	镀镍	
B	端子	黄铜H65	焊料区镀锡 接触区镀金(1U)	
A	底座	LCP	蓝色	
序号	品名	材质	电镀/颜色	备注

深圳市虹成电子有限公司

UNLESS OTHERWISE,
GENERAL TOLERANCE:

X.xxx ±0.10
X.xx ±0.20
X.x ±0.30

ANGULAR:

X.xx° ±1°
X.x° ±3°
X.° ±5°

NAME:

3.0 A母180° L13.0卷边直脚

P/N: HC-USB3.0-L130-ZJ

DWG NO:

THIRD ANGLE PROJECTION

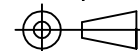

DRAWN:

UNIT:

MM

SCALE:

1:1

SIZE:

A4

SHEET:

1/1

REV.

A1

CHECKED:

APPROVED: