

RoHS 2.0

REV.	ECN NO.	DESCRIPTION	DATE	DESIGN
A0.	/	新版发行	20.04.03	yang
A1.	/	重新核对图面	21.01.07	LiHui

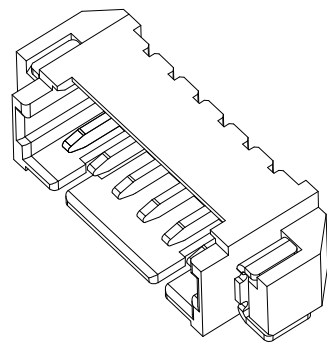

3D View

PIN数	A±0.1	B±0.1	C±0.1
2P	7.60	4.50	1.25
3P	8.85	5.75	2.50
4P	10.10	7.00	3.75
5P	11.35	8.25	5.00
6P	12.60	9.50	6.25

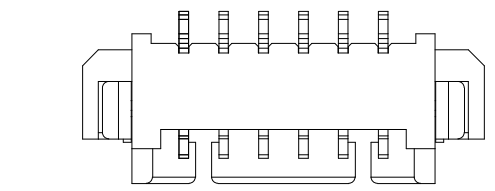

A 12.60

B 9.50

2.50

8.20

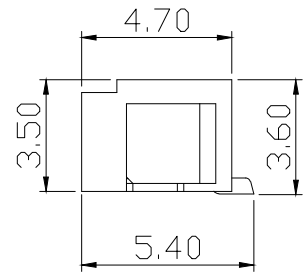

4.70

3.50

3.60

5.40

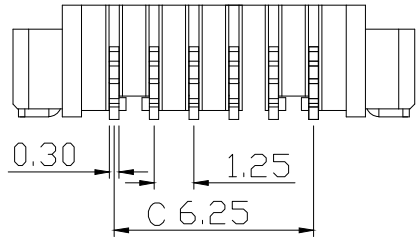

0.30

1.25

C 6.25

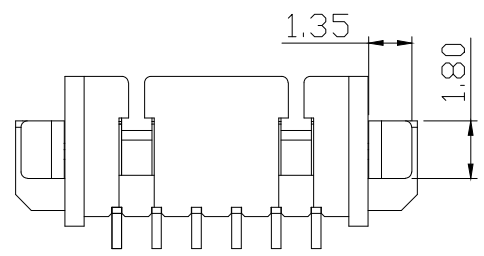

1.35

1.80

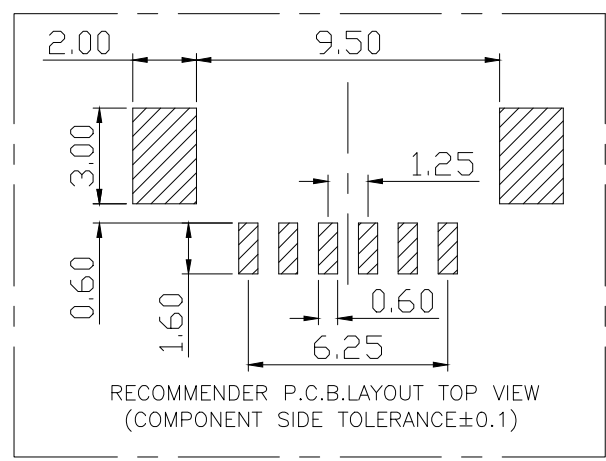

2.00

9.50

3.00

1.25

0.60

1.60

0.60

6.25

RECOMMENDER P.C.B.LAYOUT TOP VIEW  
(COMPONENT SIDE TOLERANCE±0.1)

Specifications:

1. Rated Voltage : 125V AC/DC
2. Rated Current : 1A AC,DC
3. Withstand Voltage : 200V AC/minute
4. Contact Resistance : 50mΩ(MAX.)
5. Insulation Resistance : 100MΩ(MIN.)
6. Storage Temperature Range: -40°C~+85°C;
7. Operation Temperature Range: -25°C~+70°C;

C	插片	黄铜H65	镀镍锡	
B	插针	黄铜H65	镀镍锡	
A	底座	LCP	本色	
序号	品名	材质	电镀/颜色	备注

深圳市虹成电子有限公司

UNLESS OTHERWISE, GENERAL TOLERANCE: X. xxx ±0.05 X. xx ±0.15 X. x ±0.25	NAME:	P/N: HCZZ0001-6				
	针座1.25卧贴6P		DWG NO:			
ANGULAR: X. xx° ±1° X. x° ±3° X. ° ±5°	THIRD ANGLE PROJECTION	UNIT:	SCALE:	SIZE:	SHEET:	REV.
		MM	1:1	A4	1/1	A1
DRAWN:	CHECKED:	APPROVED:				