

RoHS 2.0

REV.	ECN NO.	DESCRIPTION	DATE	DESIGN
A1.	/.	重新核对图面	21.01.08	LiHui
A2.	/.	重新核对图面	22.10.27	LZR

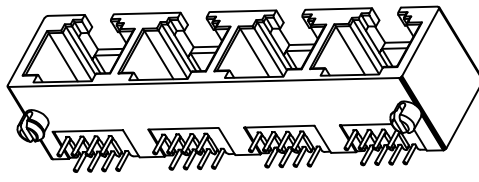

3D VIEW

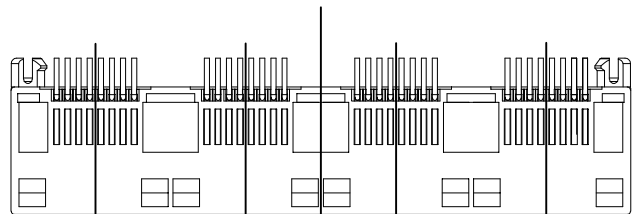
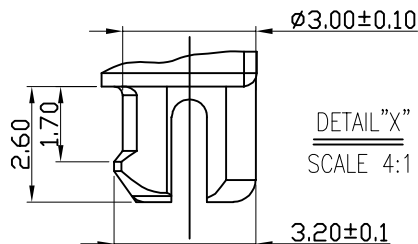
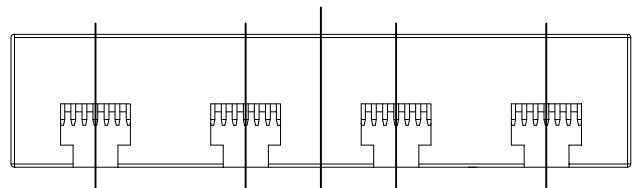

DETAIL "X"
SCALE 4:1

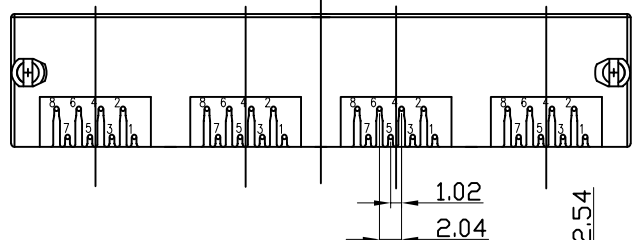
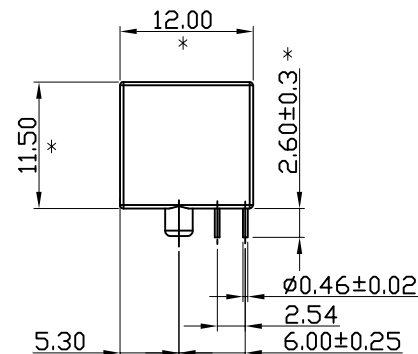
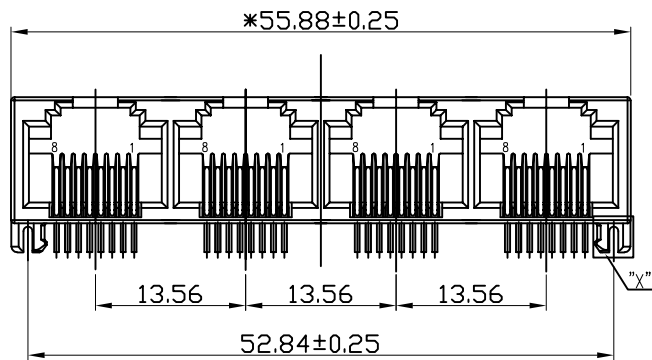

NOTES:

- MATERIAL:
 - HOUSING: PBT ,COLOUR IS YELLOW 7405C 94-V0;
 - CONTACT: PHOSPHOR BRONZE,Ø0.46±0.02mm;
- FINISH: PLATED GOLD OVER NI G/Fu";
- RECNNEBDED PCB THICKNESS: 1.60mm;
- ELECTRICAL:
 - VOLTAGE RATING: 125 VAC RMS;
 - CURRENT RATING: 1.5 AMP;
 - CONTACT RESISTANCE: 35MILLIOHMS MAX.;
 - WITHSTAND VOLTAGE: 1000 VAC RMS 50(60)Hz,1MIN.;
 - INSULATION RESISTANCE: 1000MEGOHMS MIN @500V DC;
- MECHANICAL:
 - MATING/UNMATING FORCE: 30N MAX.;
 - RETENTIION STRENGTH: 50N MIN.;
 - OPERATING LIFE: 750 CYCLES MIN.;
- SALT SPRAY TEST: 12H;
- SOLDERABILITY: 245±5°C,5±0.5S;
- RESISTANCE TO SOLDER: 260±5°C,10±1S;
- ENVIRONMENTAL:
 - STORAGE TEMPERATURE RANGE: -40°C~+85°C;
 - OPERATION TEMPERATURE RANGE: -25°C~+70°C;
- MATES WITH:MODULAR PLUGS THAT CONFORM TO FCC REGULATION PART 68.500;
- THE MARK WITH "*" IS THE KEY INSPECTION DIMENSION FOR QC.

B	端子	磷铜	镀镍 镀金(G/F)	
A	底座	PBT	黄色	
序号	品名	材质	电镀/颜色	备注

深圳市虹成电子有限公司

PART NO:
09.01.04.XXX

- 001:YELLOW 124C
- 002:YELLOW 7405C
- 003:YELLOW 114C
- 005:GRAY 3U
- 006:BLUE 300C

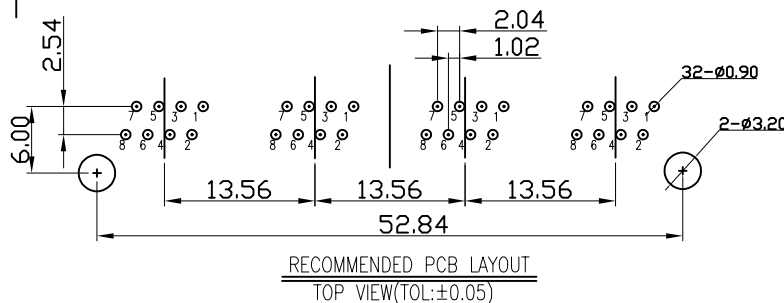

RECOMMENDED PCB LAYOUT
TOP VIEW(TOL:±0.05)

UNLESS OTHERWISE, GENERAL TOLERANCE: X.xxx ±0.10 X.xx ±0.20 X.x ±0.30	NAME: 迷你 RJ45-4口二号黄	P/N: HC-WK88-MIH12-1X4-Y2			
	THIRD ANGLE PROJECTION	UNIT: mm	SCALE: 1:1	SIZE: A4	SHEET: 1/1
ANGULAR: X.xx' ±1' X.x' ±3' X.° ±5'	DRAWN:	CHECKED:	APPROVED		