

RoHS 2.0

PIN NUMBER	SIGNAL NAME
PIN 1	Vbus
PIN 2	D-
PIN 3	D+
PIN 4	GND
PIN 5	StdA_SSRX-
PIN 6	StdA_SSRX+
PIN 7	GND_DRAIN
PIN 8	StdA_SSTX-
PIN 9	StdA_SSTX+
SHELL	GND

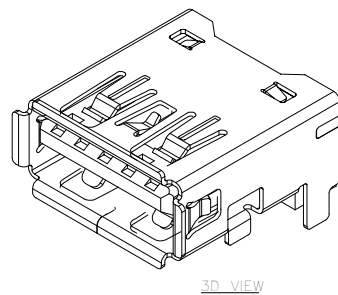

3D VIEW

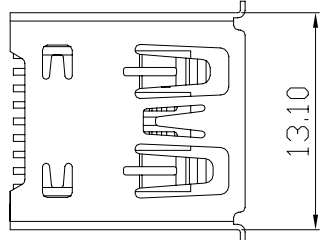
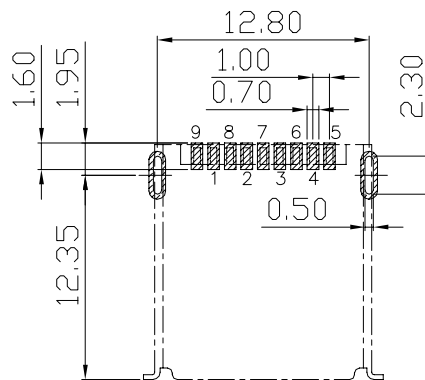
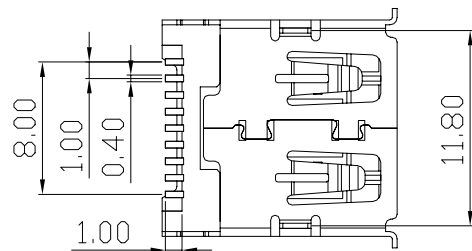
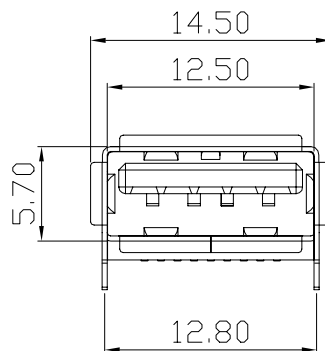
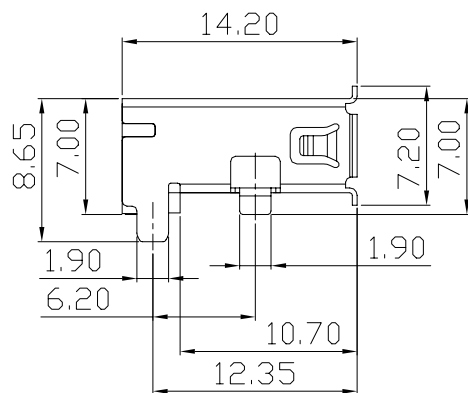

RECOMMEND PCB LAYOUT(±0.05)

REV.	ECN NO.	DESCRIPTION	DATE	DESIGN
A1.	/.	重新核对图面	21.01.04	LiHui
		HD	22.06.27	LZR

NOTES:

- MATERIAL:
 - HOUSING: LCP ,COLOR IS BLUE;
 - CONTACT: BRASS, (H65 T=0.20mm);
 - SHELL: COLD ROLLED IRON (SPCC,T=0.3mm);
- FINISH:
 - TERMINAL:
 - CONTACT AREA: GOLD PLATED G/Fu”;
 - SOLDER AREA: PLATED OVER TIN;
 - SHELL: NI PLATED OVER ALL ;
- ELECTRICAL:
 - VOLTAGE RATING: 30 VAC RMS;
 - CURRENT RATING: 1.5 AMP;
 - CONTACT RESISTANCE: 30MILLIOHMS MAX.;
 - WITHSTAND VOLTAGE: 500 VAC RMS
50(60)Hz,1MIN.;
 - INSULATION RESISTANCE: 100MEGOHMS MIN @500V DC;
- MECHANICAL:
 - MATING FORCE: 35N MAX.;
 - UNMATING FORCE: 5~35N;
 - OPERATING LIFE: 1500 CYCLES MIN.;
- ENVIRONMENTAL:
 - STORAGE TEMPERATURE RANGE: -40°C~+85°C;
 - OPERATION TEMPERATURE RANGE: -25°C~+70°C;
- SALT SPRAY TEST:24H(EXCLUDING RIVETED BENDS)

C	外壳	SPCC	镀镍	
B	端子	黄铜H65	焊料区镀锡 接触区镀金G/F	
A	基座	LCP	蓝色	
序号	品名	材质	电镀/颜色	备注

深圳市虹成电子有限公司

UNLESS OTHERWISE, GENERAL TOLERANCE: X.xxx ±0.10 X.xx ±0.20 X.x ±0.30	NAME: 3.0 A母贴板直脚卷边		P/N: HC-USB3. 0-L142-ZJ	
	DWG NO.:			
ANGULAR: X.xx° ±1° X.x° ±3° X.' ±5°	THIRD ANGLE PROJECTION	UNIT: mm	SCALE: 1:1	SIZE: A4
	DRAWN:	CHECKED:	SHEET: 1/1	REV.:
		APPROVED		