

标记 MARK	ECN编号/变更内容 ECN NO/DEFINITION	修改 REVISE	日期 DATE	核准 APPROVE

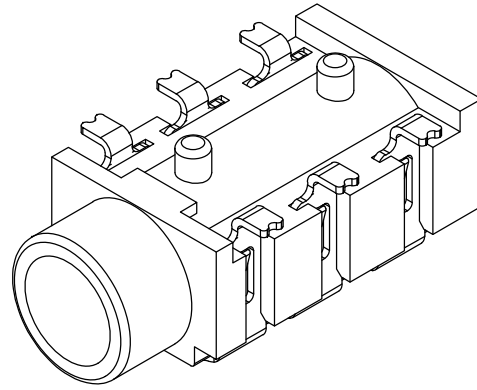

3D VIEW

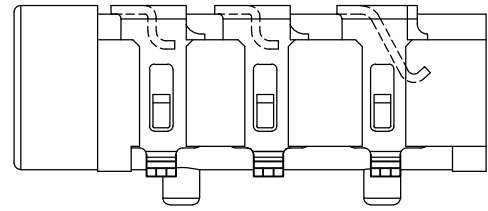
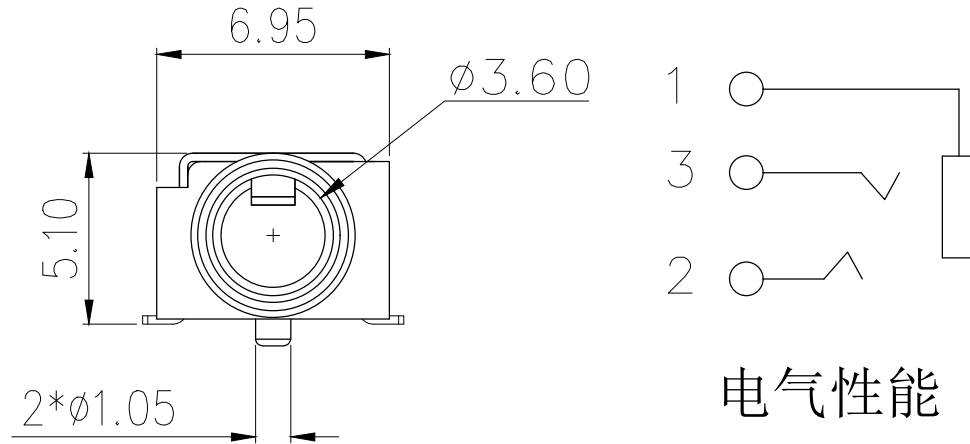
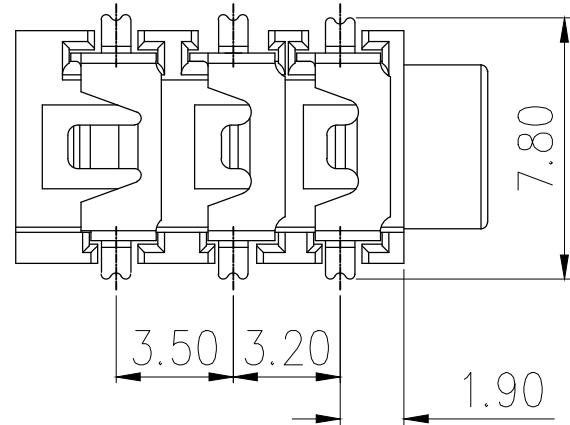

电气性能

NOTES:

- MATERIAL:
 - HOUSING: PA9T, COLOR IS BLACK;
 - CONTACT: PHOSPHOR COPPER (C5191,T=0.25mm);
- ELECTRICAL:
 - VOLTAGE RATING: 30 VAC RMS;
 - CURRENT RATING: 0.5 AMP;
 - CONTACT RESISTANCE: 30MILLIOHMS MAX.;
 - WITHSTAND VOLTAGE: 500 VAC RMS
50(60)Hz,1MIN.;
 - INSULATION RESISTANCE: 100MEGOHMS MIN
@500V DC;
- MECHANICAL:
 - MATING FORCE: 5~25N;
 - UNMATING FORCE: 5~25N;
 - OPERATING LIFE: 5000 CYCLES;
- PLATING:
 - TERMINAL:
NI PLATING OVER ALL,
TIN PLATING ON SOLDER AREA,
- ENVIRONMENTAL:
 - STORAGE TEMPERATURE RANGE: -40°C~+85°C;
 - OPERATION TEMPERATURE RANGE: -25°C~+70°C;
 - SALT SPRAY TEST: 8H(EXCLUDING RIVETED BENDS)

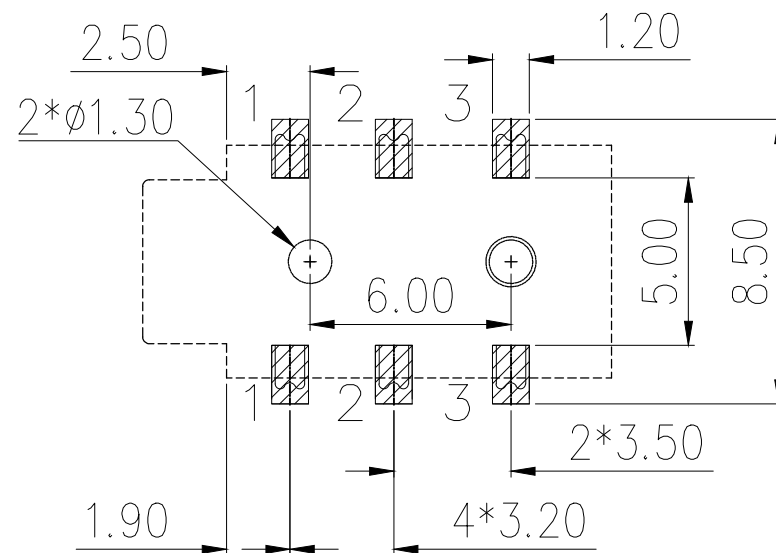
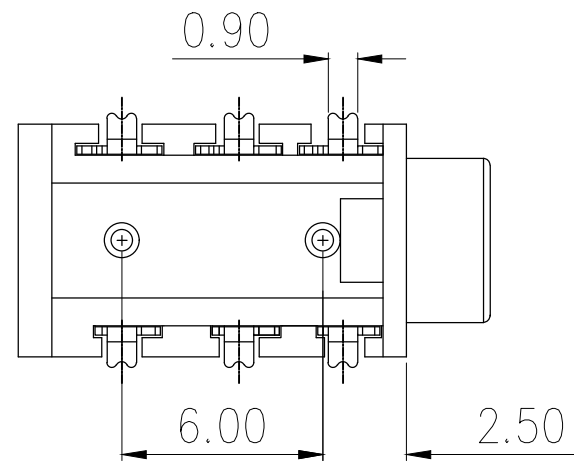

RECOMMEND PCB LAYOUT(±0.05)

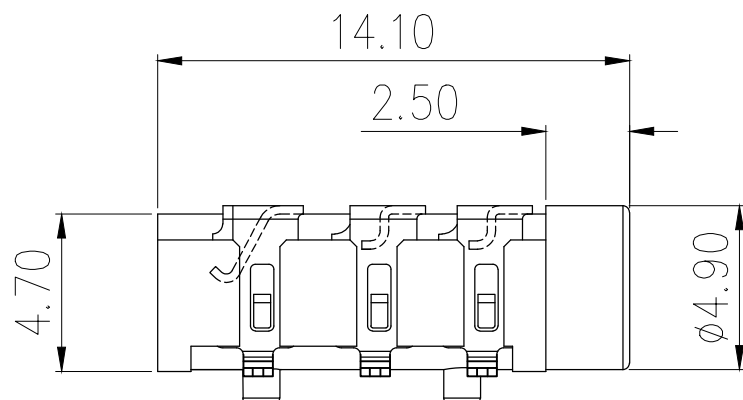

2	接触	铜	镀镍	
1	基座	PA9T	黑色	
序号	品名	材质	电镀/颜色	备注

	深圳市虹成电子有限公司		品名 TITLE	耳机座	
			料号 PART NO	HC-PJ-313D-B-SMT	
UNLESS OTHERWISE, GENERAL TOLERANCE:		比列 SCALE	1:1		
X.xxx ±0.10 X.xx ±0.20 X.x ±0.30		单位 UNIT	MM		
ANGULAR: X.xx° ±1° X.x° ±3° X.° ±5°		张数 PART NO	1 OF 1	制图 DRAW	AhYe
		版本 REV	A	审核 CHECKED	夏操云
				批准 APPROVE	赵亮亮

