

标记 MARK	ECN编号/变更内容 ECN NO/DEFINITION	修改 REVISE	日期 DATE	核准 APPROVE

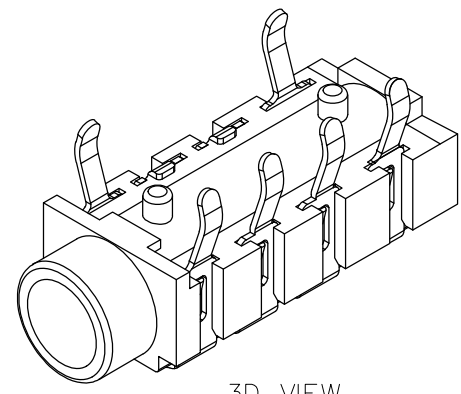
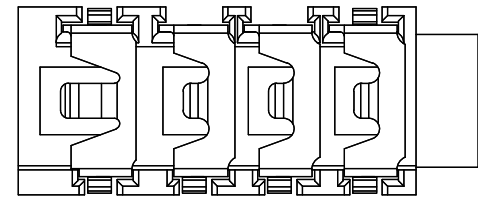

3D VIEW

NOTES

- 1. MATERIAL:
 - 1.1. HOUSING: PA46 COLOR IS BLACK;
 - 1.2. CONTACT: PHOSPHOR COPPER (C5191,T=0.25);
- 2. ELECTRICAL:
 - 2.1. VOLTAGE RATING: 30 VAC RMS;
 - 2.2. CURRENT RATING: 0.5 AMP;
 - 2.3. CONTACT RESISTANCE: 30MILLIOHMS MAX.;
 - 2.4. WITHSTAND VOLTAGE: 500 VAC RMS
50(60)Hz,1MIN.;
 - 2.5. INSULATION RESISTANCE: 100MEGOHMS MIN
@500V DC;
- 3. MECHANICAL:
 - 3.1. MATING FORCE: 5~25N;
 - 3.2. UNMATING FORCE: 5~25N;
 - 3.3. OPERATING LIFE: 5000 CYCLES;
- 4. PLATING:
 - 4.1. TERMINAL:
NI PLATING OVER ALL,
TIN PLATING ON SOLDER AREA,
- 5. ENVIRONMENTAL:
 - 5.1. STORAGE TEMPERATURE RANGE: -40°C~+85°C
 - 5.2. OPERATION TEMPERATURE RANGE: -25°C~+70°C;
- 6.SALT SPRAY TEST:8H(EXCLUDING RIVETED BENDS)

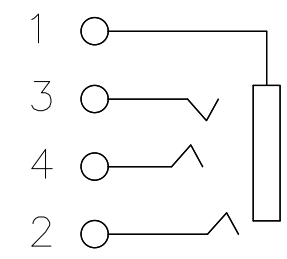
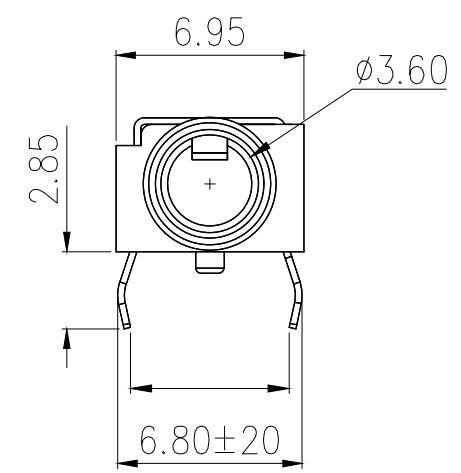
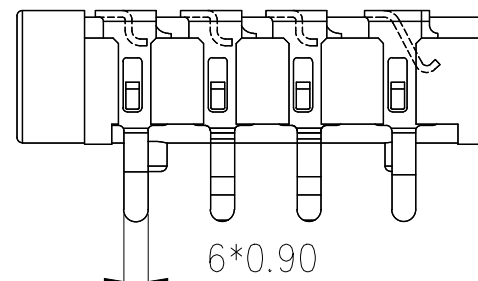

电气性能

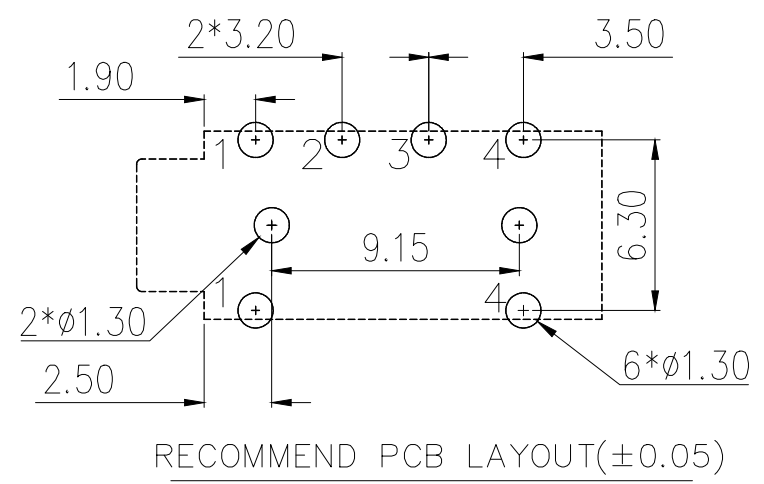
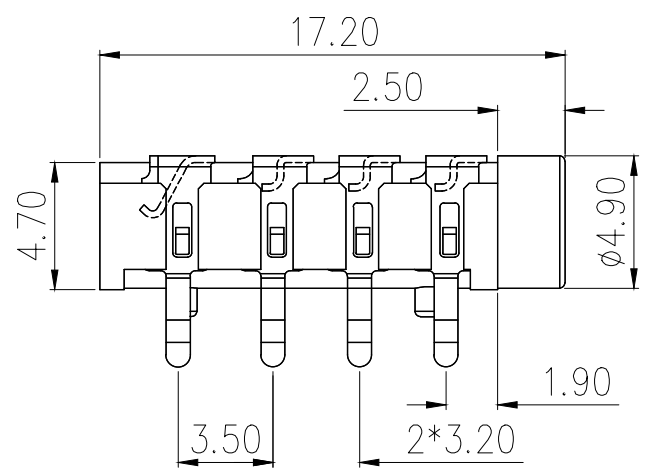
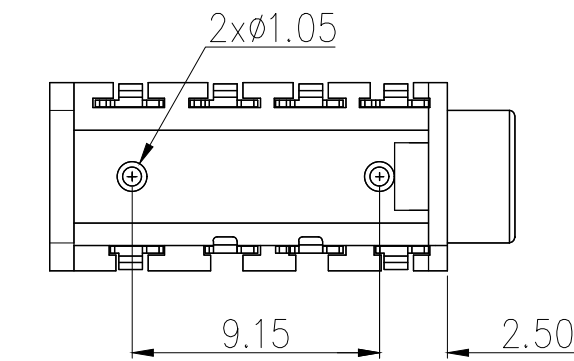

2	接触	铜	镀镍	
1	基座	PA46	黑色	
序号	品名	材质	电镀/颜色	备注

	深圳市虹成电子有限公司		品名 TITLE	耳机座	
			料号 PART NO	HC-PJ-313B6-B	
UNLESS OTHERWISE, GENERAL TOLERANCE:		比列 SCALE	1:1		
X.xxx ±0.10		单位 UNIT	MM		
X.xx ±0.20		张数 PART NO	1 OF 1		
X.x ±0.30		版本 REV	A		
ANGULAR: X.xx° ±1°		制图 DRAW	AhYe		
X.x° ±3°		审核 CHECKED	夏操云		
X.° ±5°		批准 APPROVE	赵亮亮		