

标记 MARK	ECN编号/变更内容 ECN NO/DEFINITION	修改 REVISE	日期 DATE	核准 APPROVE

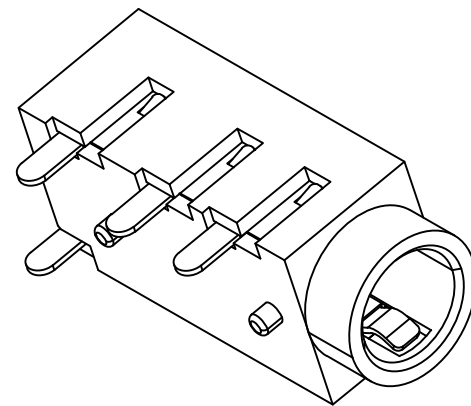

3D VIEW

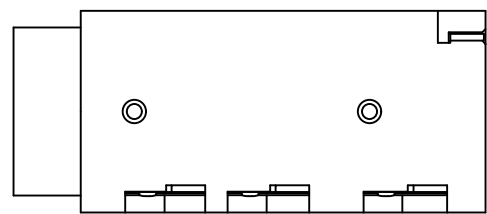
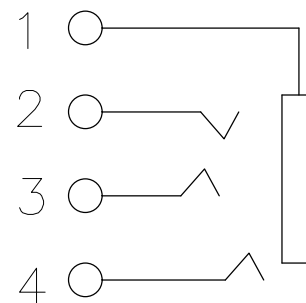
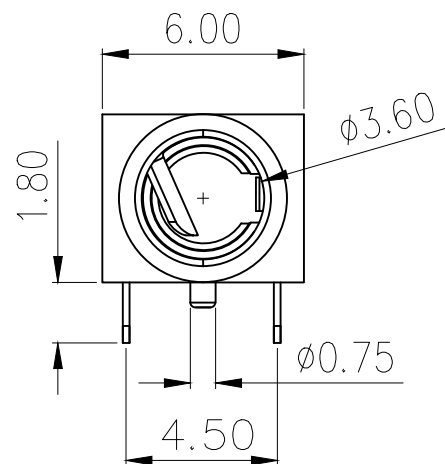
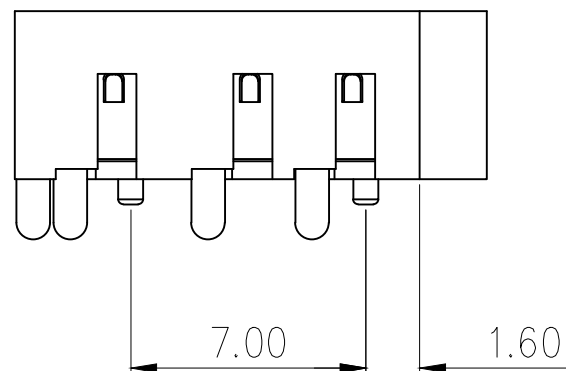
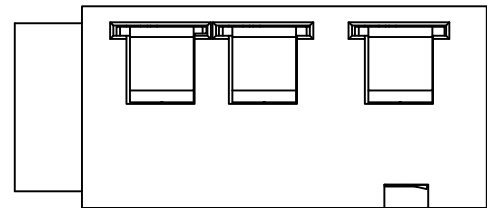

电气性能

NOTES

- MATERIAL:
  - HOUSING: LCP COLOR IS BLACK
  - CONTACT: PHOSPHOR COPPER (C5191,T=0.2mm);
- FINISH:
  - TERMINAL:
    - CONTACT AREA: NI PLATED OVER ALL;
    - SOLDER AREA: SN PLATED OVER ALL;
- ELECTRICAL:
  - VOLTAGE RATING: 30 VAC RMS;
  - CURRENT RATING: 0.5 AMP;
  - CONTACT RESISTANCE: 30MILLIOHMS MAX.;
  - WITHSTAND VOLTAGE: 500 VAC RMS  
50(60)Hz,1MIN.;
  - INSULATION RESISTANCE: 100MEGOHMS MIN  
@500V DC;
- MECHANICAL:
  - MATING FORCE: 5~25N;
  - UNMATING FORCE: 5~25N;
  - OPERATING LIFE: 5000 CYCLES;
- ENVIRONMENTAL:
  - STORAGE TEMPERATURE RANGE: -40°C~+85°C
  - OPERATION TEMPERATURE RANGE: -25°C~+70°C;
- SALT SPRAY TEST: 8H(EXCLUDING RIVETED BENDS)

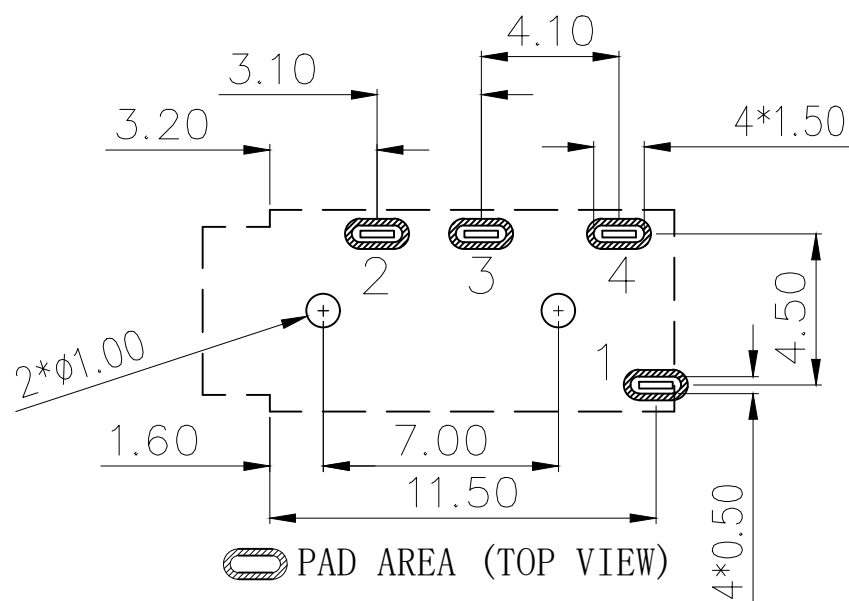
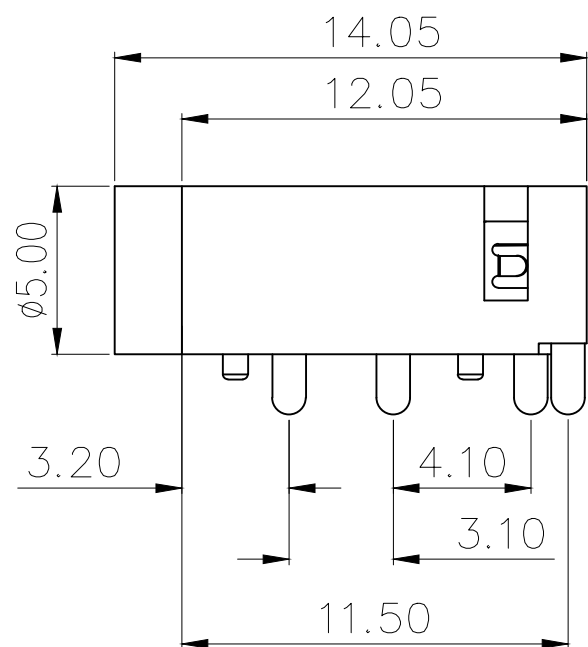

RECOMMEND PCB LAYOUT(±0.05)

2	接触	铜	镀镍	
1	基座	LCP	黑色	
序号	品名	材质	电镀/颜色	备注

	深圳市虹成电子有限公司		品名 TITLE	耳机座	
			料号 PART NO	HC-PJ-320AB	
UNLESS GENERAL TOLERANCE:	OTHERWISE, TOLERANCE:	比列 SCALE	1:1		
X.xxx ±0.10	X.xx ±0.20	单位 UNIT	MM	制图 DRAW	AhYe
X.x ±0.30	ANGULAR: X.xx° ±1°	张数 PART NO	1 OF 1	审核 CHECKED	夏操云
X.x° ±3°	X° ±5°	版本 REV	A	批准 APPROVE	赵亮亮

