

标记 MARK	ECN编号/变更内容 ECN NO/DEFINITION	修改 REVISE	日期 DATE	核准 APPROVE

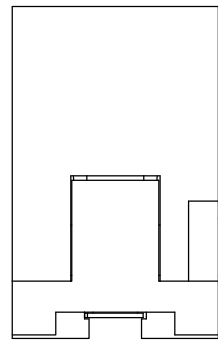

NOTES:

1. MATERIAL:
  - 1.1.HOUSING: PBT ,COLOR IS BLACK
  - 1.2.CONTACT: COLD ROLLED IRON(SPCC);
2. FINISH: PLATED OVER NI&SN;
3. RECINNEBDED PCB THICKNESS: 1.60mm MIN;
4. ELECTRICAL:
  - 4.1. VOLTAGE RATING: 30V DC ;
  - 4.2. CURRENT RATING: 1A ;
  - 4.3. CONTACT RESISTANCE: 35MILLIOHMS MAX.;
  - 4.4. WITHSTAND VOLTAGE: 500 VAC RMS 50(60)Hz,1MIN.;
  - 4.5. INSULATION RESISTANCE: 100MEGOHMS MIN @500V DC;
5. MECHANICAL:
  - 5.1. MATING FORCE: 25N MAX.;
  - 5.2. UNMATING FORCE: 3~25N ;
  - 5.3. OPERATING LIFE: 5000 CYCLES MIN.;
- 6.SALT SPRAY TEST: 12H
7. SOLDERABILITY: 245±5°C,5±0.5S;
8. RESISTANCE TO SOLDER: 260±5°C,10±1S;
9. ENVIRONMENTAL:
  - 9.1. STORAGE TEMPERATURE RANGE: -40°C~+85°C;
  - 9.2. OPERATION TEMPERATURE RANGE: -25°C~+70°C;

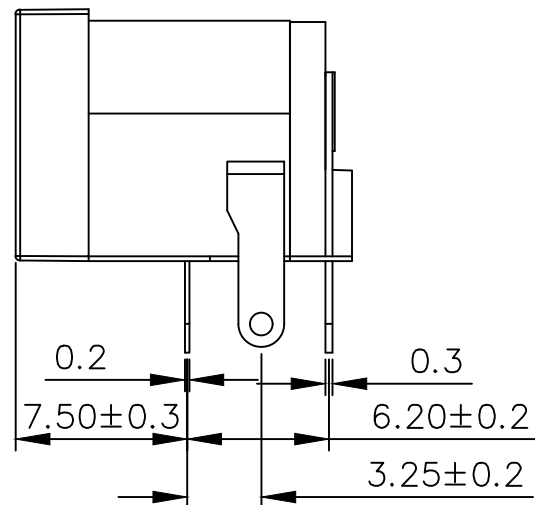
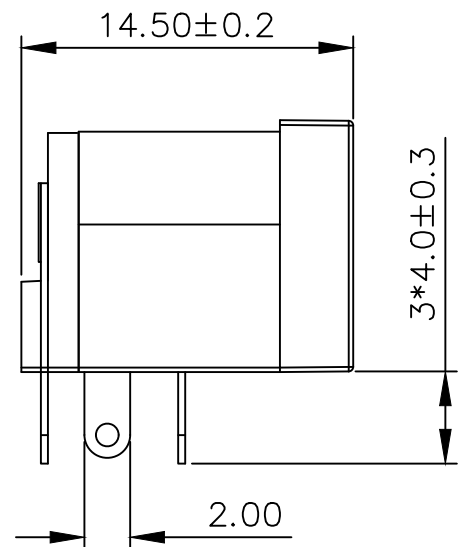
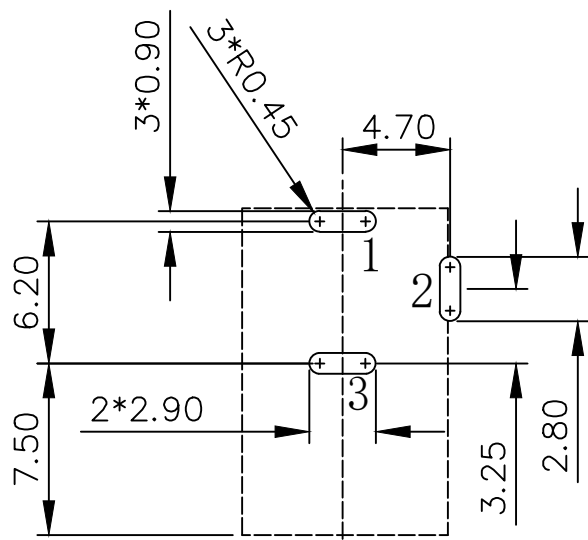
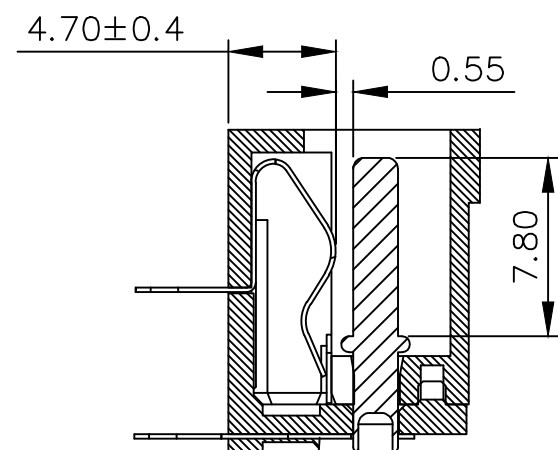
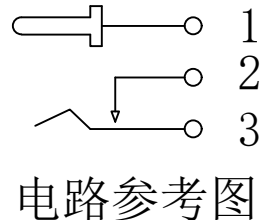
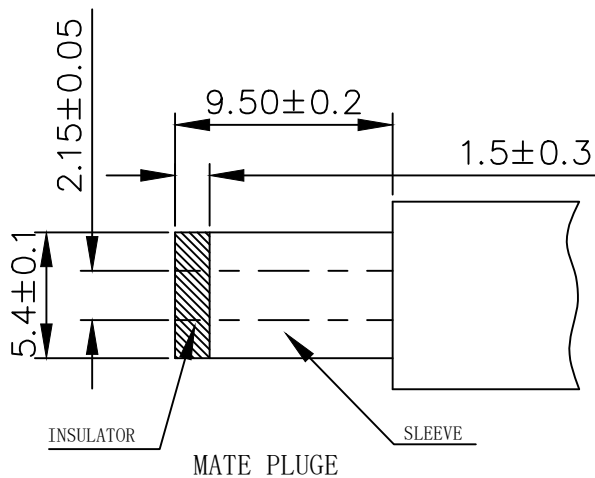
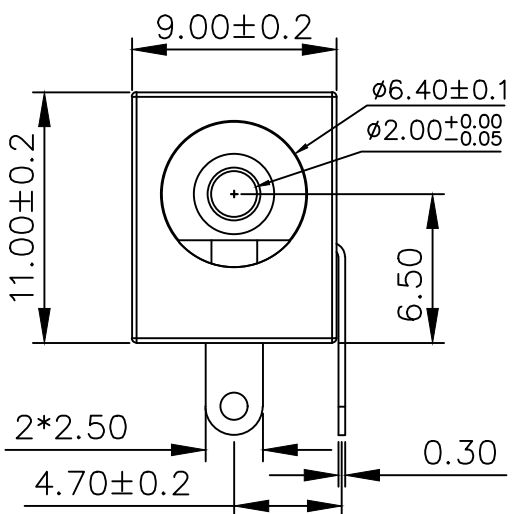

RECOMMENDED PCB LAYOUT  
TOP VIEW(TOL: ±0.05)

3	芯针	铁	镀镍锡	
2	弹片	不锈钢	镀镍锡	
1	基座	PBT	黑色	
序号	品名	材质	电镀/颜色	备注

	深圳市虹成电子有限公司 品名 TITLE DC座		
	料号 PART NO HC-DC-005-2.0-01Q		
UNLESS OTHERWISE, GENERAL TOLERANCE: X.xxx ±0.10 X.xx ±0.20 X.x ±0.30  ANGULAR: X.xx' ±1' X.x' ±3' X.' ±5'	比列 SCALE 1:1	单位 UNIT MM	制图 DRAW AhYe
	张数 PART NO 1 OF 1	版本 REV A	审核 CHECKED 夏操云
			批准 APPROVE 赵亮亮

