

标记 MARK	ECN编号/变更内容 ECN NO/DEFINITION	修改 REVISE	日期 DATE	核准 APPROVE

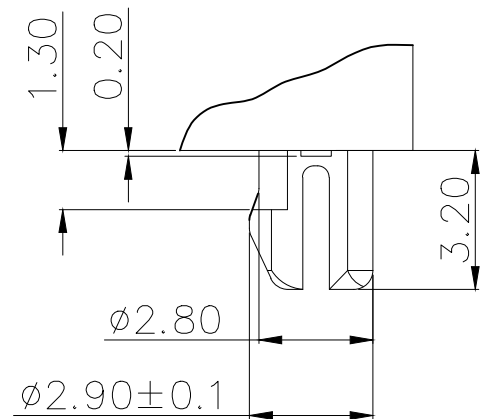

DETAIL "X"  
SCALE 2:1

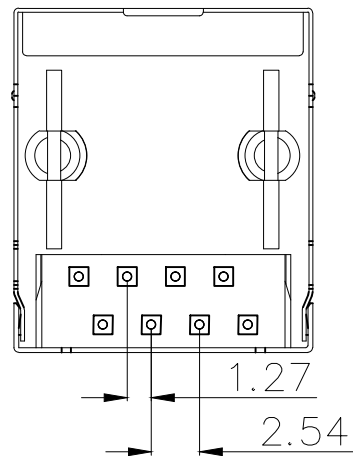
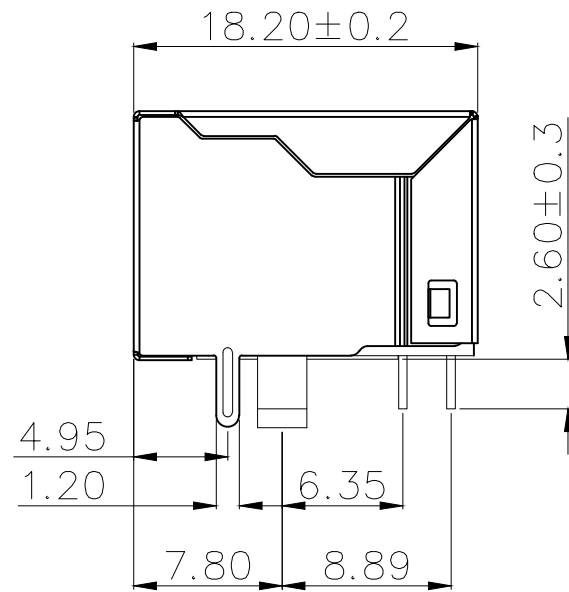
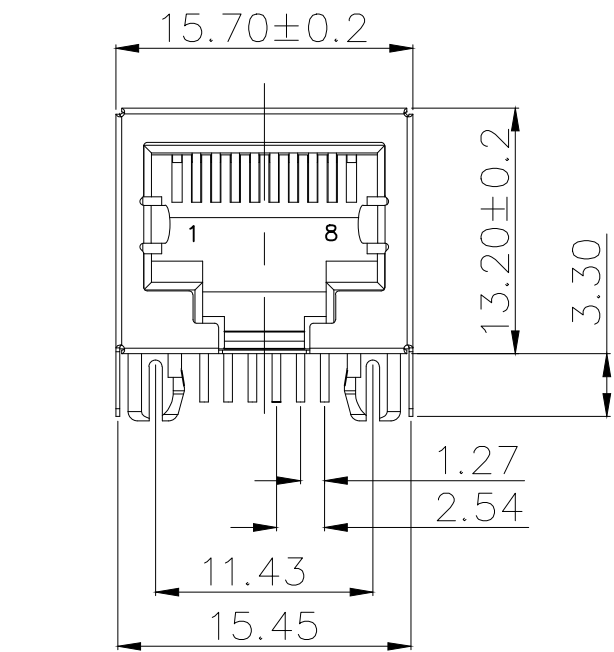
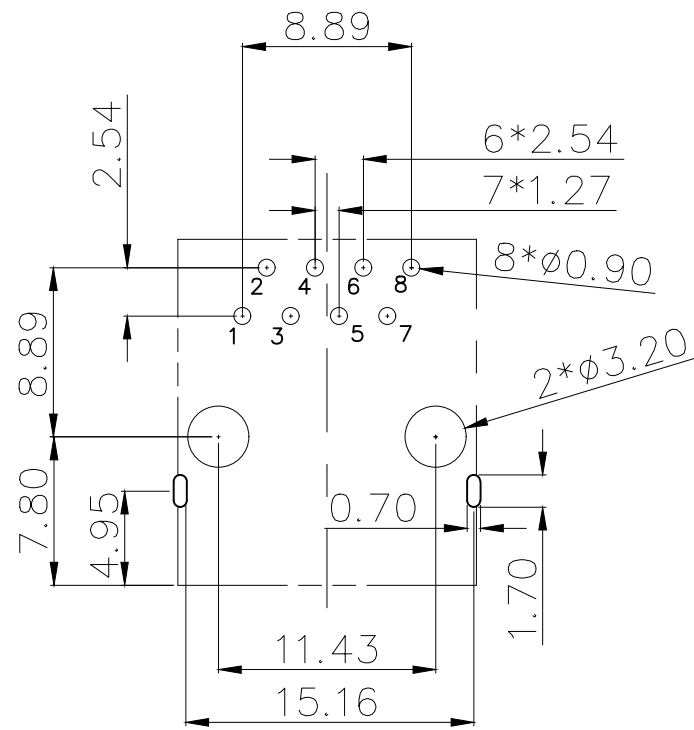

RECOMMENDED PCB LAYOUT  
TOP VIEW(TOL:±0.05)

NOTES:

- MATERIAL:
  - HOUSING: PBT ,COLOR IS BLACK ;
  - CONTACT: PHOSPHOR BRONZE,φ0.46±0.02mm;
  - SHELL: SUS T=0.2mm;
- FINISH: PLATED GOLD OVER NI;
- RECINNEBDED PCB THICKNESS: 1.2~1.60mm;
- ELECTRICAL:
  - VOLTAGE RATING: 125 VAC RMS;
  - CURRENT RATING: 1.5 AMP;
  - CONTACT RESISTANCE: 35MILLIOHMS MAX.;
  - WITHSTAND VOLTAGE: 1000 VAC RMS 50(60)Hz,1MIN.;
  - INSULATION RESISTANCE: 1000MEGOHMS MIN @500V DC.;
- MECHANICAL:
  - MATING/UNMATING FORCE: 22N MAX.;
  - RETENTIION STRENGTH: 50N MIN.;
  - OPERATING LIFE: 750 CYCLES MIN.;
- SALT SPRAY TEST: 12H;
- SOLDERABILITY: 245±5°C,5±0.5S;
- RESISTANCE TO SOLDER: 260±5°C,10±1S;
- ENVIRONMENTAL:
  - STORAGE TEMPERATURE RANGE: -40°C~+85°C;
  - OPERATION TEMPERATURE RANGE: -25°C~+70°C;

3	外壳	不锈钢	镀镍	
2	接触	铜	镀金G/F	
1	基座	PBT	黑色	
序号	品名	材质	电镀/颜色	备注



深圳市虹成电子有限公司

品名 TITLE	网口
料号 PART NO	HC-WK88-H18-K

UNLESS OTHERWISE, GENERAL TOLERANCE:	比列 SCALE	1:1		
X. xxx ±0.10 X. xx ±0.20 X. x ±0.30	单位 UNIT	MM	制图 DRAW	AhYe
ANGULAR: X. xx° ±1° X. x° ±3° X. ° ±5°	张数 PART NO	1 OF 1	审核 CHECKED	夏操云
	版本 REV	A	批准 APPROVE	赵亮亮

