

标记 MARK	ECN编号/变更内容 ECN NO/DEFINITION	修改 REVISE	日期 DATE	核准 APPROVE

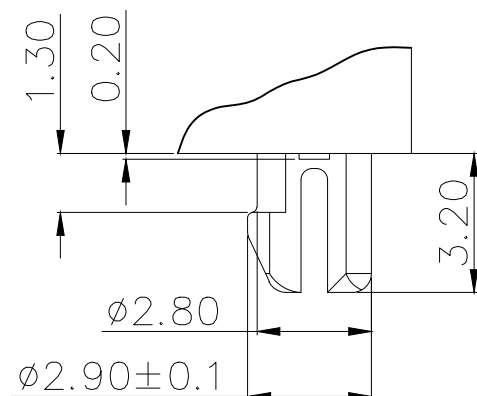

DETAIL "X"
SCALE 2:1

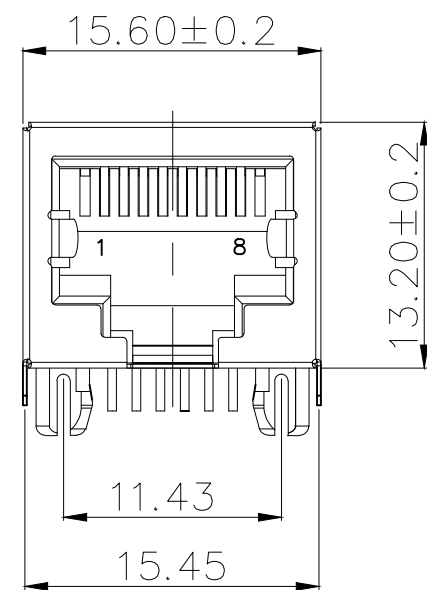
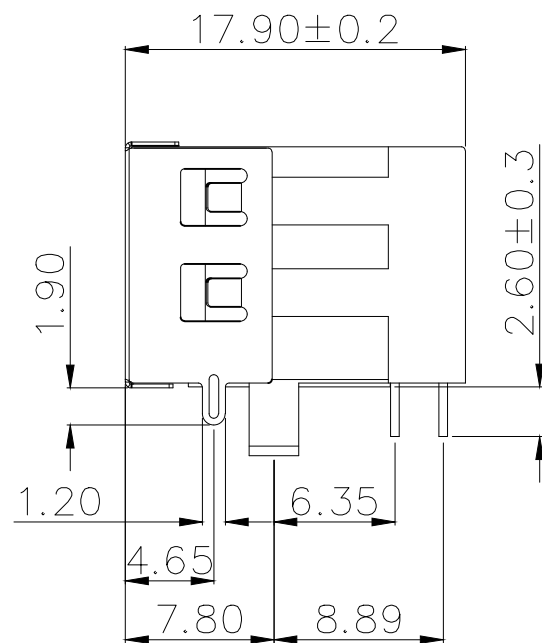
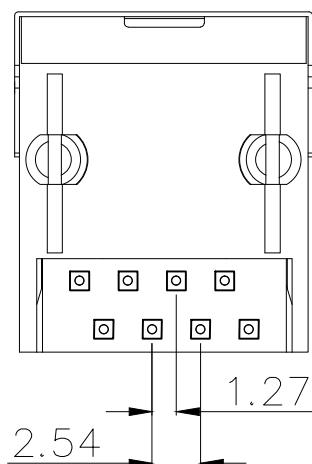
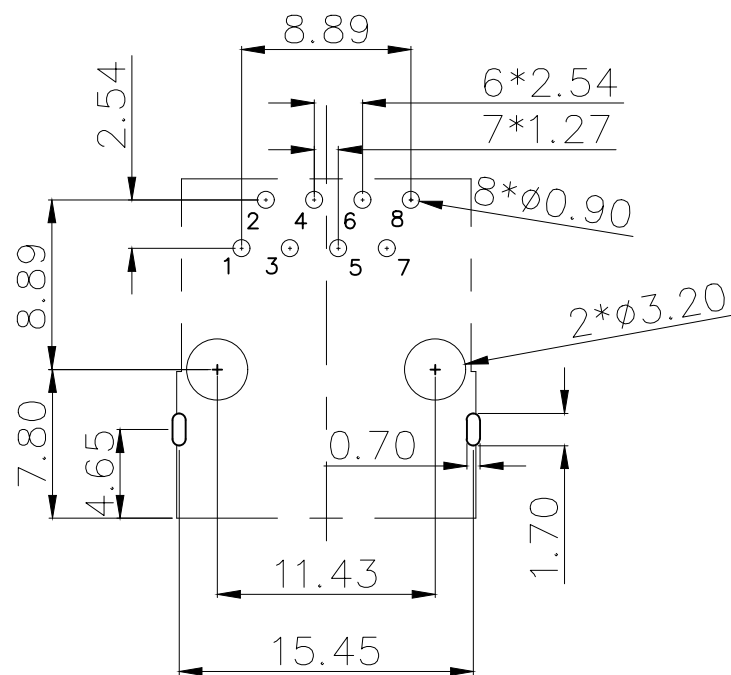

RECOMMENDED PCB LAYOUT
TOP VIEW(TOL:±0.05)

NOTES:

- MATERIAL:
 - HOUSING: PBT , COLOR IS BLACK;
 - CONTACT: PHOSPHOR BRONZE, $\phi 0.46\text{mm}$;
 - SHELL: STAINLESS STEEL, $T=0.20\text{mm}$
- FINISH:
 - CONTACT: PLATED GOLD OVER NI;
 - SHELL: PLATED NI OVER ALL
- RECINNEBDED PCB THICKNESS: 1.2~1.60mm;
- ELECTRICAL:
 - VOLTAGE RATING: 125 VAC RMS;
 - CURRENT RATING: 1.5 AMP;
 - CONTACT RESISTANCE: 35MILLIOHMS MAX.;
 - WITHSTAND VOLTAGE: 1000 VAC RMS 50(60)Hz,1MIN.;
 - INSULATION RESISTANCE: 1000MEGOHMS MIN @500V DC.;
- MECHANICAL:
 - MATING/UNMATING FORCE: 22N MAX.;
 - RETENTIION STRENGTH: 50N MIN.;
 - OPERATING LIFE: 750 CYCLES MIN.;
- SALT SPRAY TEST: 12H;
- SOLDERABILITY: 245±5°C,5±0.5S;
- RESISTANCE TO SOLDER: 260±5°C,10±1S;
- ENVIRONMENTAL:
 - STORAGE TEMPERATURE RANGE: -40°C~+85°C;
 - OPERATION TEMPERATURE RANGE: -25°C~+70°C;

3	外壳	不锈钢	镀镍	
2	接触	铜	镀金G/F	
1	基座	PBT	黑色	
序号	品名	材质	电镀/颜色	备注

	深圳市虹成电子有限公司 TITLE 网口 PART NO HC-WK88-H18-B		品名 网口	
	UNLESS OTHERWISE, GENERAL TOLERANCE: X. xxx ±0.10 X. xx ±0.20 X. x ±0.30 ANGULAR: X. xx° ±1° X. x° ±3° X. ° ±5°	比列 SCALE 1:1	单位 UNIT MM	张数 PART NO 1 OF 1
	版本 REV A	审核 CHECKED 夏操云	批准 APPROVE 赵亮亮	