

标记 MARK	ECN编号/变更内容 ECN NO/DEFINITION	修改 REVISE	日期 DATE	核准 APPROVE

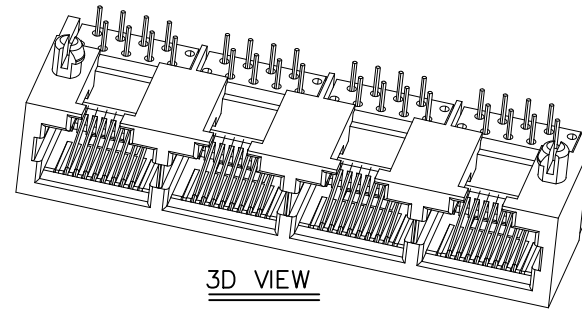

NOTES:

- MATERIAL:
  - HOUSING: PBT ,COLOR IS YELLOW ,124C;
  - CONTACT: PHOSPHOR BRONZE,  $\phi 0.46 \pm 0.02 \text{mm}$ ;
- FINISH: PLATED GOLD OVER NI;
- RECINNEBDED PCB THICKNESS: 1.60mm;
- ELECTRICAL:
  - VOLTAGE RATING: 125 VAC RMS;
  - CURRENT RATING: 1.5 AMP;
  - CONTACT RESISTANCE: 35MILLIOHMS MAX.;
  - WITHSTAND VOLTAGE: 1000 VAC RMS 50(60)Hz,1MIN.;
  - INSULATION RESISTANCE: 1000MEGOHMS MIN @500V DC.;
- MECHANICAL:
  - MATING/UNMATING FORCE: 22N MAX.;
  - RETENTION STRENGTH: 50N MIN.;
  - OPERATING LIFE: 750 CYCLES MIN.;
- SALT SPRAY TEST: 12H;
- SOLDERABILITY:  $245 \pm 5^\circ \text{C}, 5 \pm 0.5 \text{S}$ ;
- RESISTANCE TO SOLDER:  $260 \pm 5^\circ \text{C}, 10 \pm 1 \text{S}$ ;
- ENVIRONMENTAL:
  - STORAGE TEMPERATURE RANGE:  $-40^\circ \text{C} \sim +85^\circ \text{C}$ ;
  - OPERATION TEMPERATURE RANGE:  $-25^\circ \text{C} \sim +70^\circ \text{C}$ ;
- MATES WITH: MODULAR PLUGS THAT CONFORM TO FCC REGULATION PART 68.500;

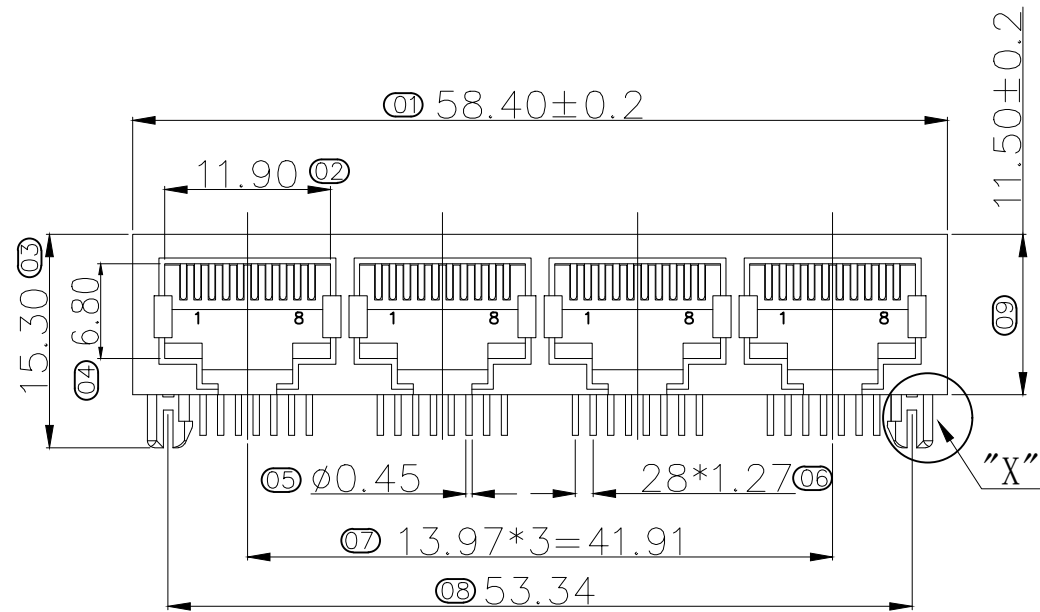
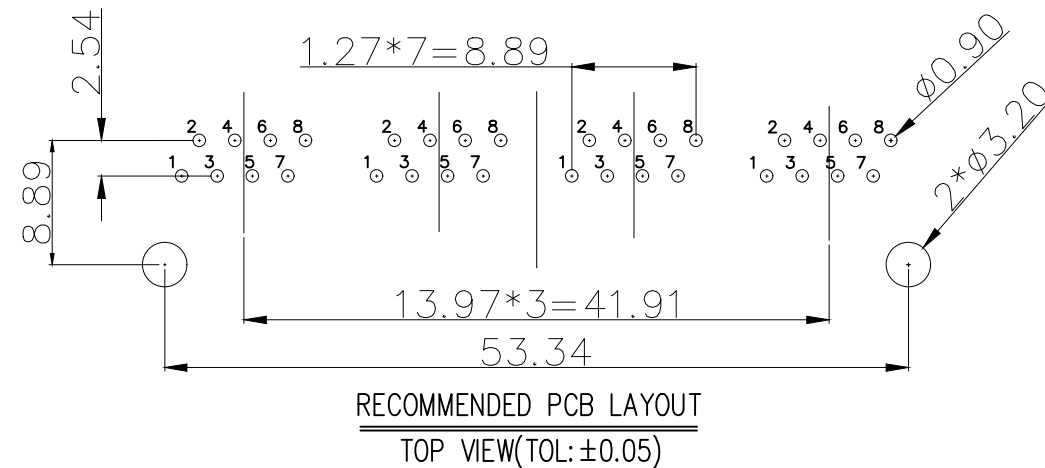
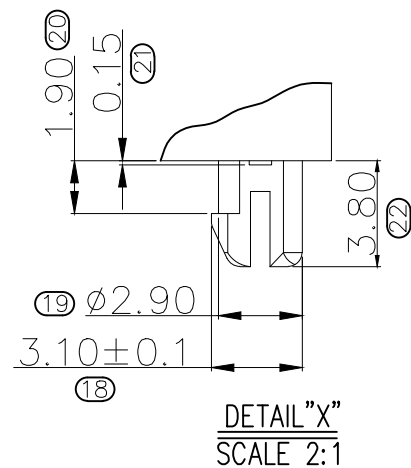
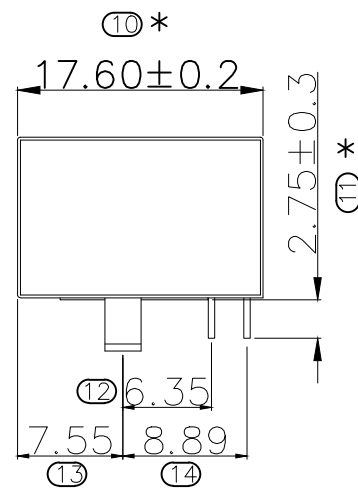
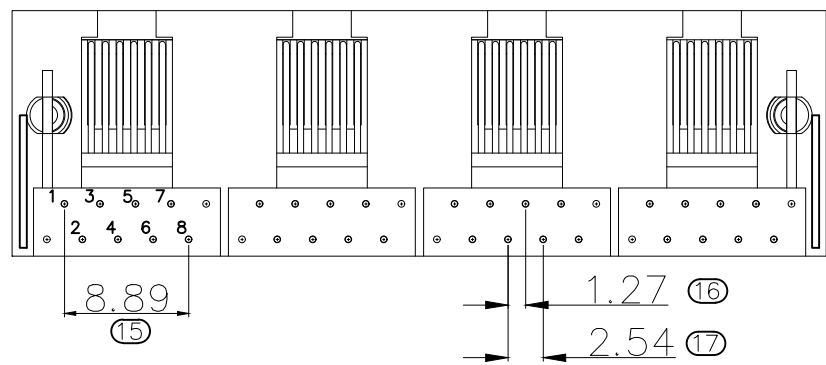

2	接触	铜	镀金G/F	
1	基座	PBT	黄色	
序号	品名	材质	电镀/颜色	备注

	深圳市虹成电子有限公司		品名 TITLE	网口	
			料号 PART NO	HC-WK108-H18-1X4-56B	
UNLESS OTHERWISE, GENERAL TOLERANCE:		比列 SCALE	1:1		
X. xxx $\pm 0.10$		单位 UNIT	MM		
X. xx $\pm 0.20$		张数 PART NO	1 OF 1		
X. x $\pm 0.30$		版本 REV	A		
ANGULAR: X. xx° $\pm 1^\circ$		制图 DRAW	AhYe		
X. x° $\pm 3^\circ$		审核 CHECKED	夏操云		
X. ° $\pm 5^\circ$		批准 APPROVE	赵亮亮		