

标记 MARK	ECN编号/变更内容 ECN NO/DEFINITION	修改 REVISE	日期 DATE	核准 APPROVE

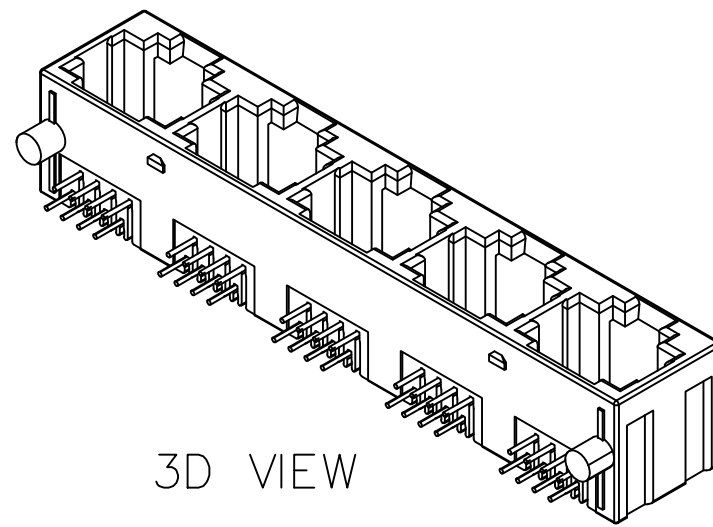

3D VIEW

NOTES:

1. MATERIAL:
 - 1.1. HOUSING: PBT ,COLOR IS BLACK;
 - 1.2. CONTACT: PHOSPHOR BRONZE, $\phi 0.46 \pm 0.02 \text{mm}$;
3. RECINNEBDED PCB THICKNESS: 1.0mm Min;
4. ELECTRICAL:
 - 4.1. VOLTAGE RATING: 125 VAC RMS;
 - 4.2. CURRENT RATING: 1.5 AMP;
 - 4.3. CONTACT RESISTANCE: 35MILLIOHMS MAX.;
 - 4.4. WITHSTAND VOLTAGE: 1000 VAC RMS 50(60)Hz, 1MIN.;
 - 4.5. INSULATION RESISTANCE: 1000MEGOHMS MIN @500V DC;
5. MECHANICAL:
 - 5.1. MATING/UNMATING FORCE: 30N MAX.;
 - 5.2. RETENTIION STRENGTH: 50N MIN.;
 - 5.3. OPERATING LIFE: 750 CYCLES MIN.;
6. SALT SPRAY TEST: 12H;
7. SOLDERABILITY: $245 \pm 5^\circ \text{C}, 5 \pm 0.5 \text{S}$;
8. RESISTANCE TO SOLDER: $260 \pm 5^\circ \text{C}, 10 \pm 1 \text{S}$;
9. ENVIRONMENTAL:
 - 8.1. STORAGE TEMPERATURE RANGE: $-40^\circ \text{C} \sim +85^\circ \text{C}$;
 - 8.2. OPERATION TEMPERATURE RANGE: $-25^\circ \text{C} \sim +70^\circ \text{C}$;

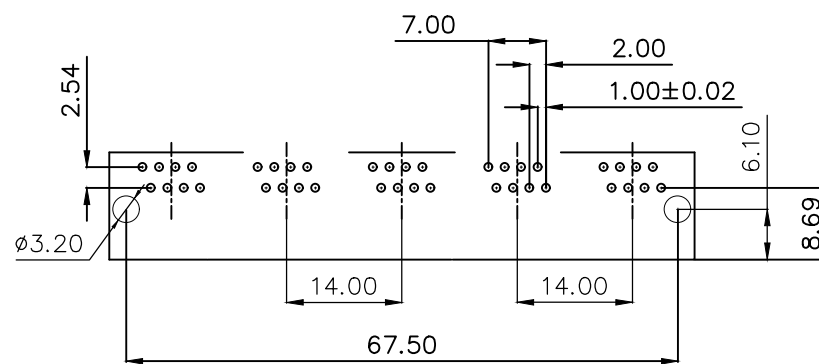
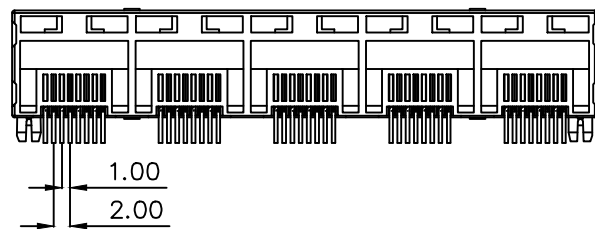
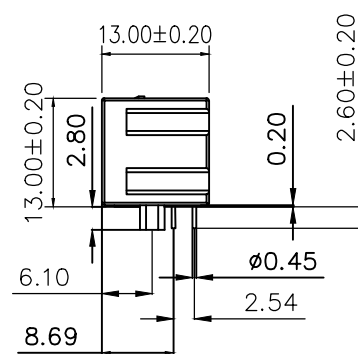
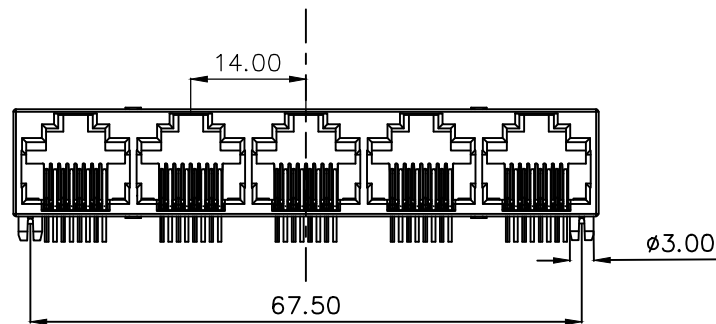

RECOMMENDED PCB LAYOUT
TOP VIEW(TOL: ± 0.05)

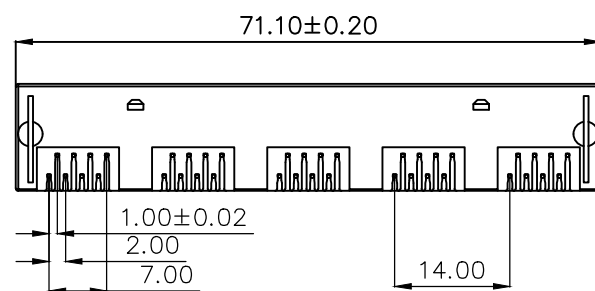

2	接触	铜	镀金G/F	
1	基座	PBT	黑色	
序号	品名	材质	电镀/颜色	备注

	深圳市虹成电子有限公司		品名 TITLE	网口	
			料号 PART NO	HC-WK88-H13-1X5-55QS	
UNLESS OTHERWISE, GENERAL TOLERANCE:		比列 SCALE	1:1		
X.xxx ± 0.10	X.xx ± 0.20	单位 UNIT	MM	制图 DRAW	AhYe
X.x ± 0.30		张数 PART NO	1 OF 1	审核 CHECKED	夏操云
ANGULAR: X.xx° $\pm 1^\circ$ X.x° $\pm 3^\circ$ X.° $\pm 5^\circ$		版本 REV	A	批准 APPROVE	赵亮亮

