

标记 MARK	ECN编号/变更内容 ECN NO/DEFINITION	修改 REVISE	日期 DATE	核准 APPROVE

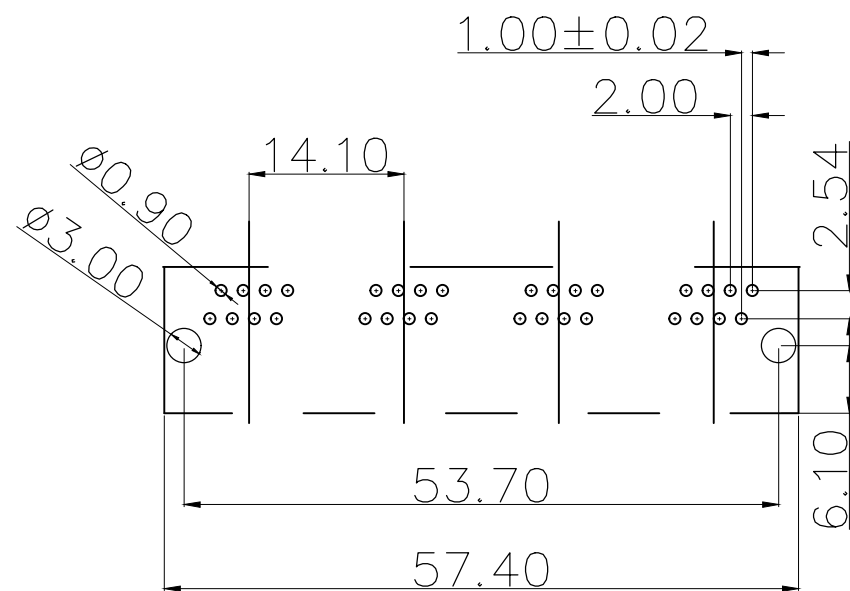
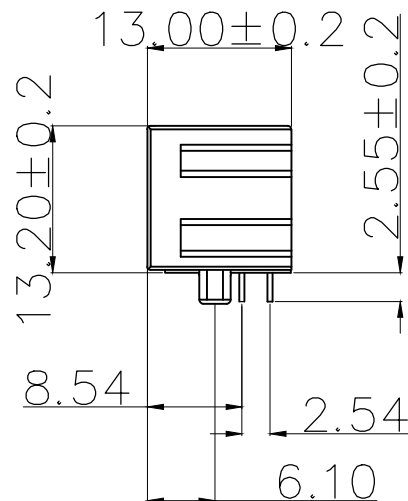
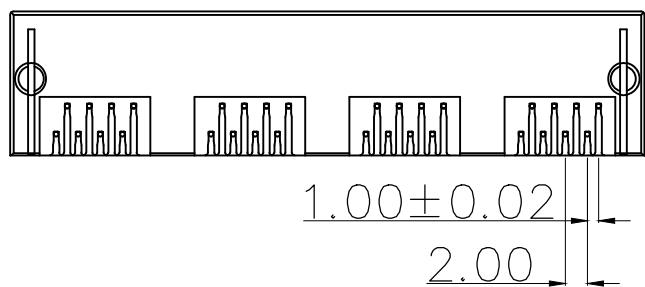
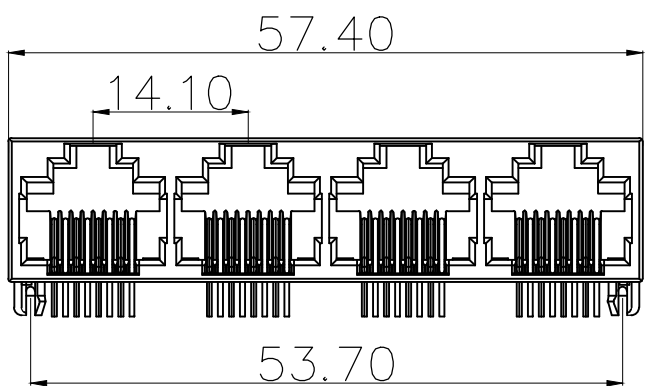
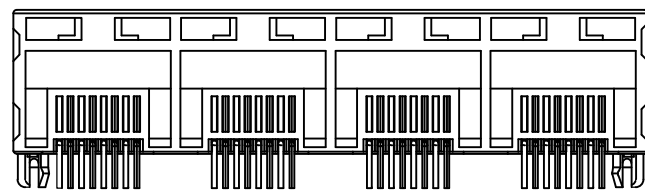

RECOMMENDED PCB LAYOUT
TOP VIEW(TOL: ±0.05)

NOTES:

- MATERIAL:
 - HOUSING: PBT ,COLOR IS BLACK;
 - CONTACT: PHOSPHOR BRONZE, $\phi 0.46 \pm 0.02$ mm;
- FINISH: CONTACT: PLATED GOLD OVER NI;
- RECINNEBDED PCB THICKNESS: 1.0mm Min;
- ELECTRICAL:
 - VOLTAGE RATING: 125 VAC RMS;
 - CURRENT RATING: 1.5 AMP;
 - CONTACT RESISTANCE: 35MILLIOHMS MAX.;
 - WITHSTAND VOLTAGE: 1000 VAC RMS 50(60)Hz,1MIN.;
 - INSULATION RESISTANCE: 1000MEGOHMS MIN @500V DC;
- MECHANICAL:
 - MATING/UNMATING FORCE: 30N MAX.;
 - RETENTIION STRENGTH: 50N MIN.;
 - OPERATING LIFE: 750 CYCLES MIN.;
- SALT SPRAY TEST: 12H;
- SOLDERABILITY: $245 \pm 5^\circ\text{C}$, 5 ± 0.5 S;
- ENVIRONMENTAL:
 - STORAGE TEMPERATURE RANGE: $-40^\circ\text{C} \sim +85^\circ\text{C}$;
 - OPERATION TEMPERATURE RANGE: $-25^\circ\text{C} \sim +70^\circ\text{C}$;

2	接触	铜	镀金G/F	
1	基座	PBT	黑色	
序号	品名	材质	电镀/颜色	备注

	深圳市虹成电子有限公司 TITLE: 网口 RJ55 PART NO: HC-WK88-H13-1X4-55QS			
	UNLESS OTHERWISE, GENERAL TOLERANCE: X.xxx ±0.10 X.xx ±0.20 X.x ±0.30 ANGULAR: X.xx° ±1° X.x° ±3° X.° ±5°	比列 SCALE 1:1	单位 UNIT MM	制图 DRAW AhYe
张数 PART NO 1 OF 1	版本 REV A	审核 CHECKED 夏操云	批准 APPROVE 赵亮亮	