

2	3	4	5	6	7	8	9
标记 MARK	ECN编号/变更内容 ECN NO/DEFINITION	修改 REVISE	日期 DATE	核准 APPROVE			

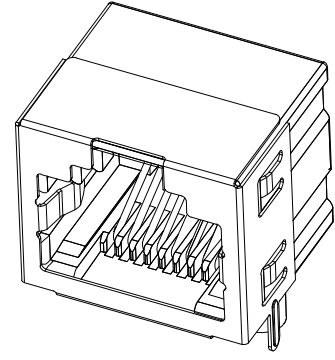

3D VIEW

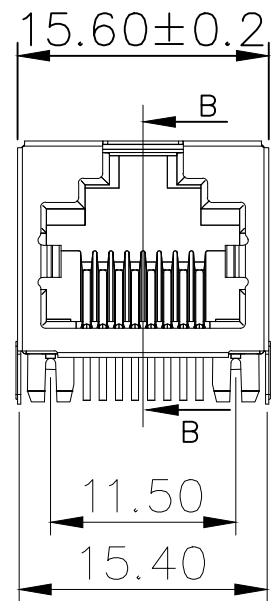
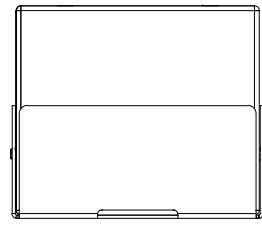
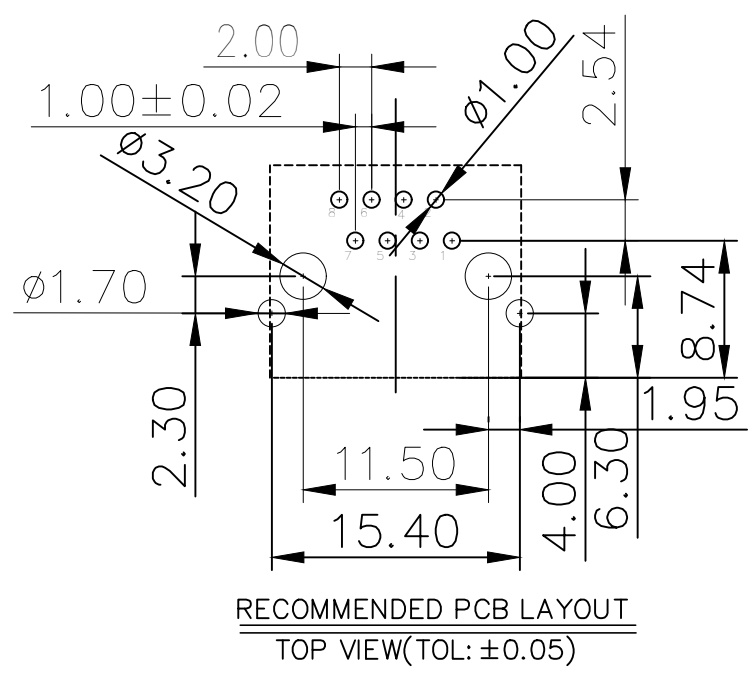
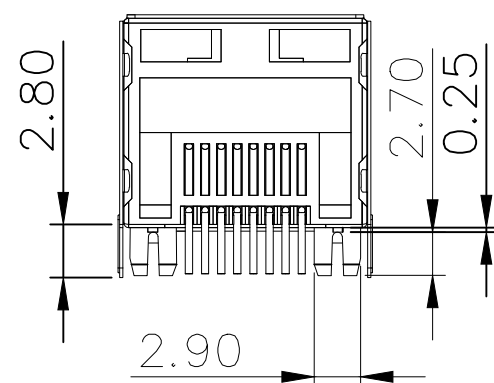
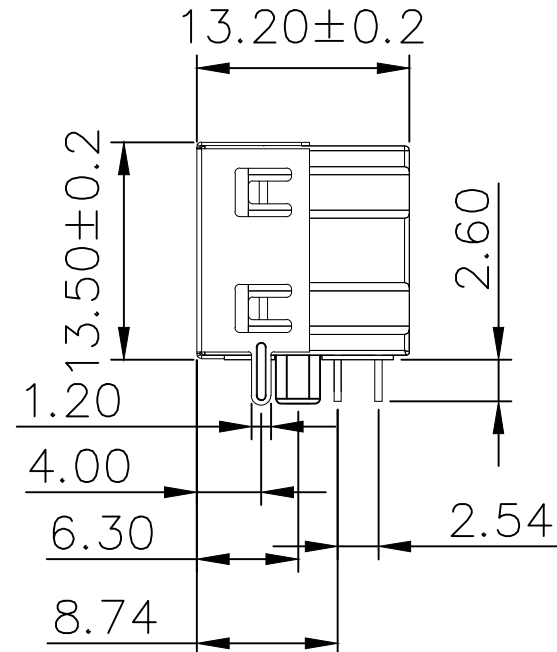

- NOTES:
- MATERIAL:
    - HOUSING: PBT ,COLOR IS BLACK ;
    - CONTACT: PHOSPHOR BRONZE,  $\phi 0.46 \pm 0.02$ mm;
    - SHELL: Stainless steel material;
  - FINISH:
    - CONTACT: PLATED GOLD OVER NI;
    - SHELL: PLATED OVER NI;
  - RECINNEBDED PCB THICKNESS: 1.0mm Min;
  - ELECTRICAL:
    - VOLTAGE RATING: 125 VAC RMS;
    - CURRENT RATING: 1.5 AMP;
    - CONTACT RESISTANCE: 35MILLIOHMS MAX.;
    - WITHSTAND VOLTAGE: 1000 VAC RMS 50(60)Hz,1MIN.;
    - INSULATION RESISTANCE: 1000MEGOHMSPMIN @500V DC;
  - MECHANICAL:
    - MATING/UNMATING FORCE: 30N MAX.;
    - RETENTION STRENGTH: 50N MIN.;
    - OPERATING LIFE: 750 CYCLES MIN.;
  - SALT SPRAY TEST: 12H;
  - SOLDERABILITY:  $245 \pm 5^\circ\text{C}, 5 \pm 0.5\text{S}$ ;
  - RESISTANCE TO SOLDER:  $260 \pm 5^\circ\text{C}, 10 \pm 1\text{S}$ ;
  - ENVIRONMENTAL:
    - STORAGE TEMPERATURE RANGE:  $-40^\circ\text{C} \sim +85^\circ\text{C}$ ;
    - OPERATION TEMPERATURE RANGE:  $-25^\circ\text{C} \sim +70^\circ\text{C}$ ;

3	外壳	不锈钢	镀镍	
2	接触	铜	镀金G/F	
1	基座	PBT	黑色	
序号	品名	材质	电镀/颜色	备注

	深圳市虹成电子有限公司 品名 TITLE: 网口 料号 PART NO: HC-WK88-H132-55B		
	UNLESS OTHERWISE, GENERAL TOLERANCE: X.xxx ±0.10 X.xx ±0.20 X.x ±0.30  ANGULAR: X.xx° ±1° X.x° ±3° X.° ±5°	比列 SCALE: 1:1 单位 UNIT: MM 张数 PART NO: 1 OF 1 版本 REV: A	

