

标记 MARK	ECN编号/变更内容 ECN NO/DEFINITION	修改 REVISE	日期 DATE	核准 APPROVE

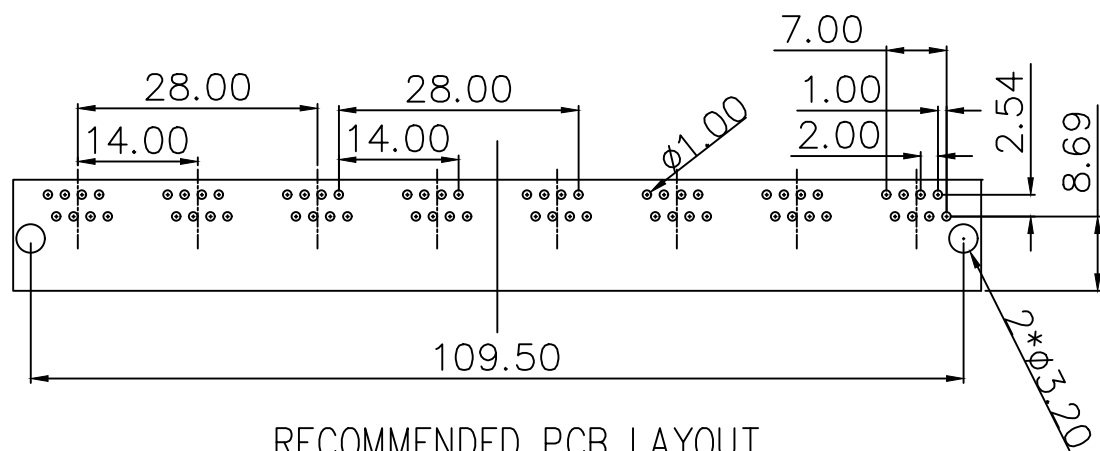

RECOMMENDED PCB LAYOUT
TOP VIEW(TOL:±0.05)

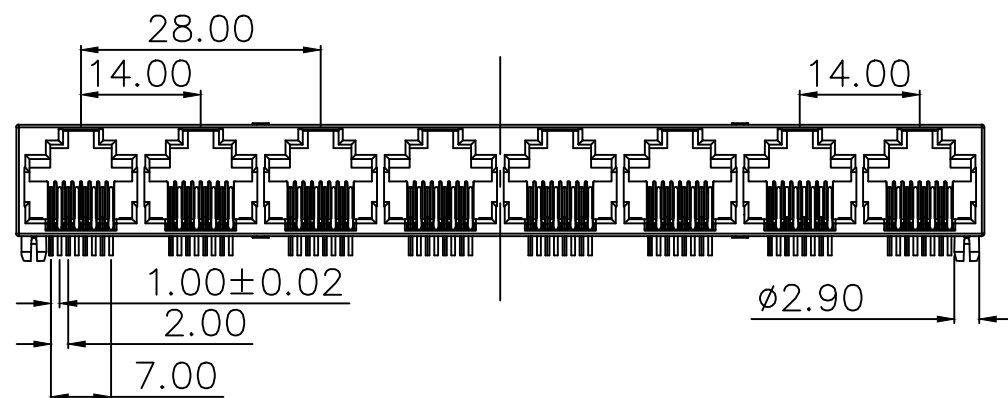
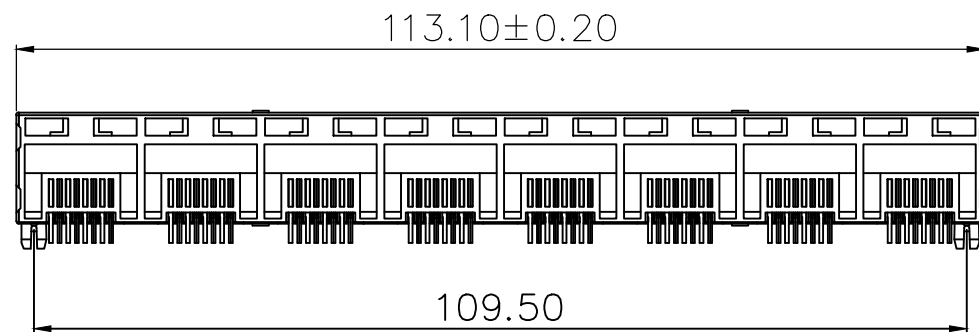
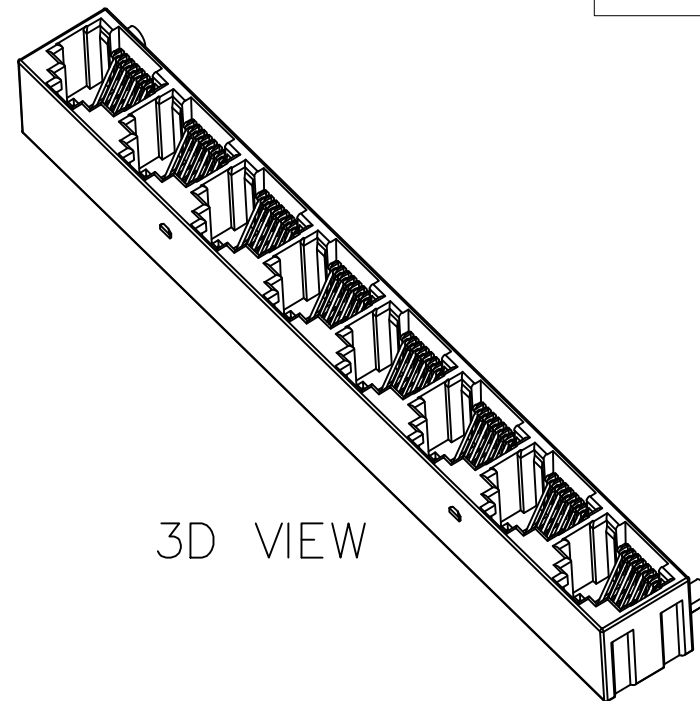

3D VIEW

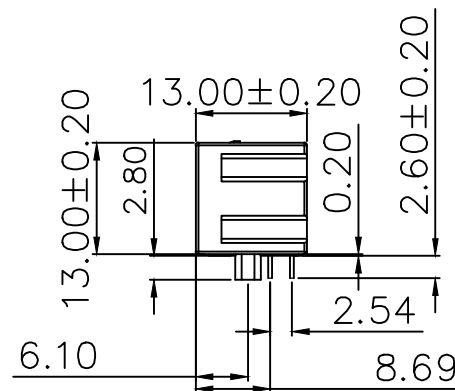

NOTES:

- MATERIAL:
 - HOUSING: PBT ,COLOR IS BLACK;
 - CONTACT: PHOSPHOR BRONZE, $\phi 0.46 \pm 0.02 \text{mm}$;
- RECINNEBDED PCB THICKNESS: 1.0mm Min;
- ELECTRICAL:
 - VOLTAGE RATING: 125 VAC RMS;
 - CURRENT RATING: 1.5 AMP;
 - CONTACT RESISTANCE: 35MILLIOHMS MAX.;
 - WITHSTAND VOLTAGE: 1000 VAC RMS 50(60)Hz, 1MIN.;
 - INSULATION RESISTANCE: 1000MEGOHMS MIN @500V DC;
- MECHANICAL:
 - MATING/UNMATING FORCE: 30N MAX.;
 - RETENTION STRENGTH: 50N MIN.;
 - OPERATING LIFE: 750 CYCLES MIN.;
- SALT SPRAY TEST: 12H;
- SOLDERABILITY: $245 \pm 5^\circ \text{C}, 5 \pm 0.5 \text{S}$;
- RESISTANCE TO SOLDER: $260 \pm 5^\circ \text{C}, 10 \pm 1 \text{S}$;
- ENVIRONMENTAL:
 - STORAGE TEMPERATURE RANGE: $-40^\circ \text{C} \sim +85^\circ \text{C}$;
 - OPERATION TEMPERATURE RANGE: $-25^\circ \text{C} \sim +70^\circ \text{C}$;

2	接触	铜	镀金G/F	
1	基座	PBT	黑色	
序号	品名	材质	电镀/颜色	备注

深圳市虹成电子有限公司 品名 TITLE 网口 料号 PART NO HC-WK88-H13-1X8-55QS		品名 TITLE 网口 料号 PART NO HC-WK88-H13-1X8-55QS		
		比例 SCALE 1:1		
UNLESS OTHERWISE, GENERAL TOLERANCE: X.xxx ±0.10 X.xx ±0.20 X.x ±0.30 ANGULAR: X.xx° ±1° X.x° ±3° X.° ±5°		单位 UNIT MM	制图 DRAW AhYe	
		张数 PART NO 1 OF 1	审核 CHECKED 夏操云	
		版本 REV A	批准 APPROVE 赵亮亮	