

标记 MARK	ECN编号/变更内容 ECN NO/DEFINITION	修改 REVISE	日期 DATE	核准 APPROVE

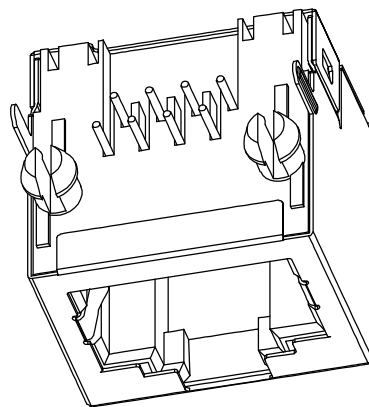
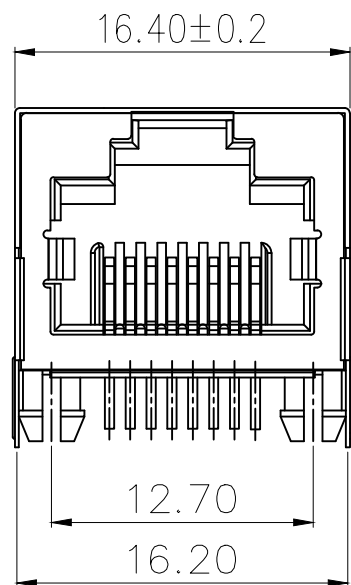

3D VIEW

NOTES:

1. MATERIAL:
 - 1.1. HOUSING: PBT ,COLOR IS BLACK;
 - 1.2. CONTACT: PHOSPHOR BRONZE, $\phi 0.46 \pm 0.02$ mm;
 - 1.3. SHELL: BRASS T= 0.2 ± 0.22 mm ;
2. FINISH:
 - 2.1 CONTACT: PLATED GOLD OVER NI;
 - 2.2 SHELL: NI OVER ALL;
3. RECINNEBDED PCB THICKNESS: 1.60mm;
4. ELECTRICAL:
 - 4.1. VOLTAGE RATING: 125 VAC RMS;
 - 4.2. CURRENT RATING: 1.5 AMP;
 - 4.3. CONTACT RESISTANCE: 35MILLIOHMS MAX.;
 - 4.4. WITHSTAND VOLTAGE: 1000 VAC RMS 50(60)Hz,1MIN.;
 - 4.5. INSULATION RESISTANCE: 1000MEGOHMS MIN @500V DC;
5. MECHANICAL:
 - 5.1. MATING/UNMATING FORCE: 25N MAX.;
 - 5.2. RETENTIION STRENGTH: 50N MIN.;
 - 5.3. OPERATING LIFE: 750 CYCLES MIN.;
6. SALT SPRAY TEST: 12H (Excluding riveted bends);
7. SOLDERABILITY: $245 \pm 5^\circ\text{C}, 5 \pm 0.5\text{S}$;
8. RESISTANCE TO SOLDER: $260 \pm 5^\circ\text{C}, 10 \pm 1\text{S}$;
9. ENVIRONMENTAL:
 - 9.1. STORAGE TEMPERATURE RANGE: $-40^\circ\text{C} \sim +85^\circ\text{C}$;
 - 9.2. OPERATION TEMPERATURE RANGE: $-40^\circ\text{C} \sim +85^\circ\text{C}$;
10. MATES WITH: MODULAR PLUGS THAT CONFORM TO FCC REGULATION PART 68.500;

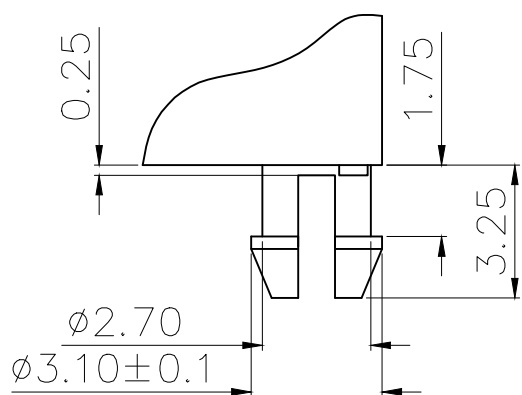
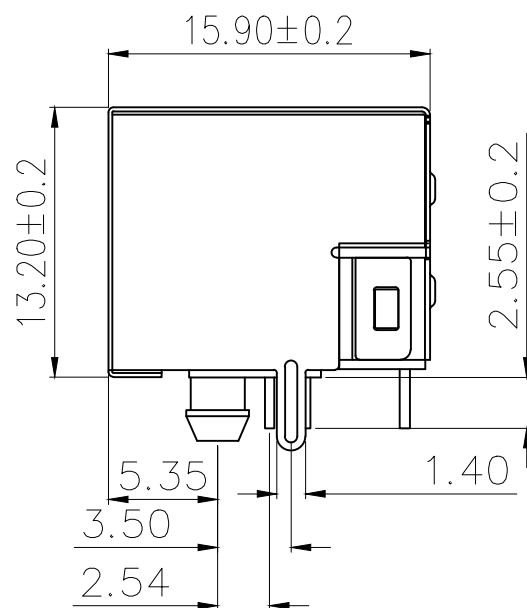
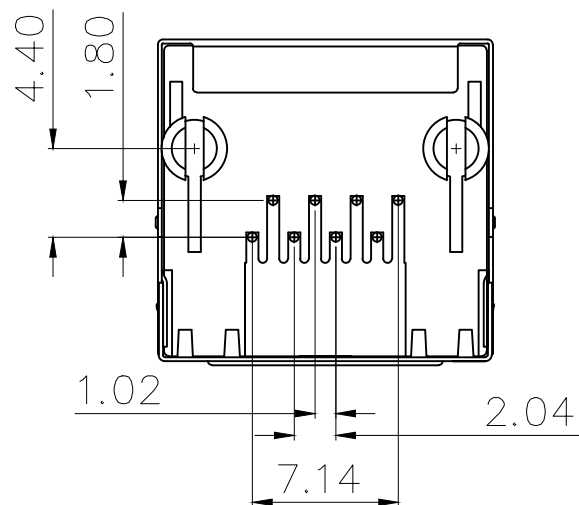

DETAIL "X"
SCALE 2:1

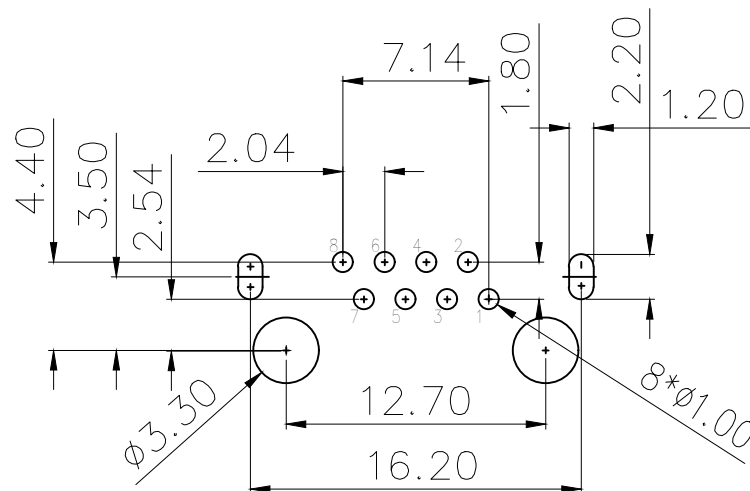

RECOMMENDER P. C. B. LAYOUT TOP VIEW
(COMPONENT SIDE TOLERANCE ± 0.05)

3	外壳	铜	镀镍	
2	接触	铜	镀金G/F	
1	基座	PBT	黑色	
序号	品名	材质	电镀/颜色	备注

	深圳市虹成电子有限公司		品名 TITLE	网口	
			料号 PART NO	HC-WK88-H16-K	
UNLESS OTHERWISE, GENERAL TOLERANCE:		比列 SCALE	1:1		
X. xxx ±0.10 X. xx ±0.20 X. x ±0.30		单位 UNIT	MM	制图 DRAW	AhYe
ANGULAR: X. xx° ±1° X. x° ±3° X. ° ±5°		张数 PART NO	1 OF 1	审核 CHECKED	夏操云
		版本 REV	A	批准 APPROVE	赵亮亮

