

标记 MARK	ECN编号/变更内容 ECN NO/DEFINITION	修改 REVISE	日期 DATE	核准 APPROVE

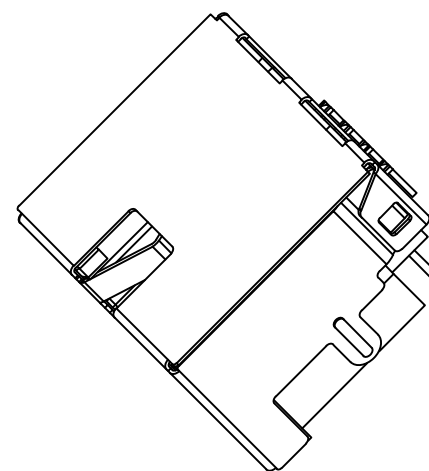

3D VIEW

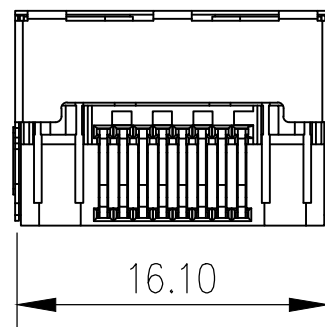
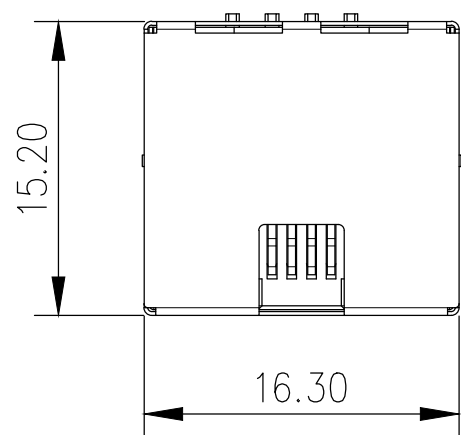
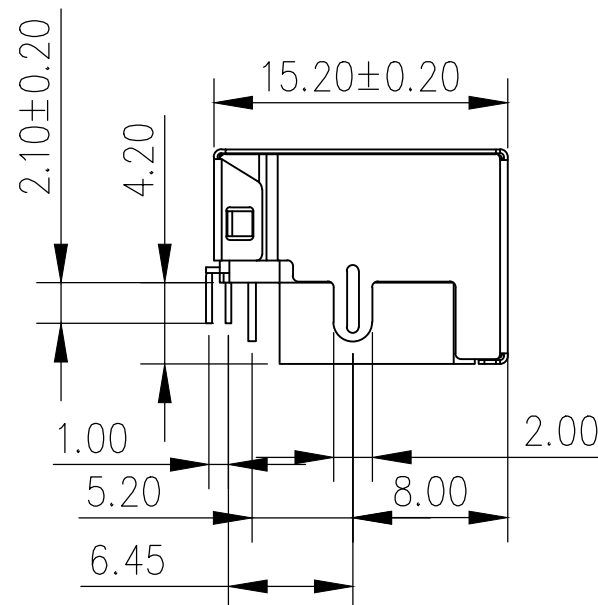
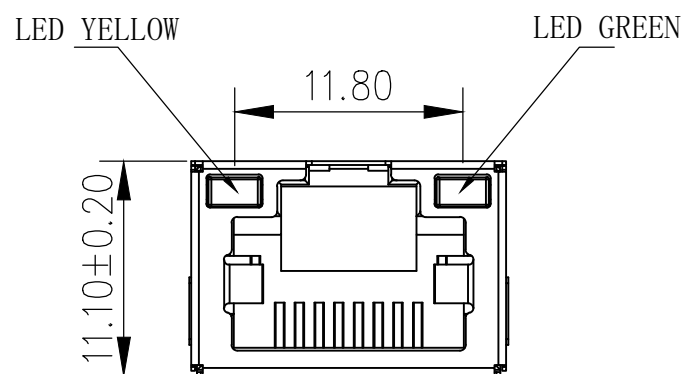

NOTES:

1.MATERIAL:

- 1.1 HOUSING: LCP ,COLOR IS BLACK;
- 1.2. CONTACT: PHOSPHOR COPPER ;

2.FINISH: GOLD PLATED G/Fu”;

4.ELECTRICAL:

- 4.1 VOLTAGE RATING: 125 VAC RMS;
- 4.2 CURRENT RATING: 1.5 AMP;
- 4.3 CONTACT RESISTANCE: 35MILLIOHMS MAX.;
- 4.4 WITHSTAND VOLTAGE: 500 VAC RMS 50(60)Hz,1MIN.;
- 4.5 INSULATION RESISTANCE: 500MEGOHMS MIN @500V DC.;

5.MECHANICAL:

- 5. 1MATING/UNMATING FORCE: 22N MAX.;
- 5. 2RETENTIION STRENGTH: 50N MIN.;
- 5. 3OPERATING LIFE: 750 CYCLES MIN.;

6.ENVIRONMENTAL:

- 6.1 STORAGE TEMPERATURE RANGE: -40°C~+85°C;
- 6.2 OPERATION TEMPERATURE RANGE: -25°C~+70°C;

7.SALT SPRAY TEST:8H(EXCLUDING RIVETED BENDS)

3	外壳	不锈钢	镀镍	
2	接触	铜	镀金G/F	
1	基座	LCP	黑色	
序号	品名	材质	电镀/颜色	备注

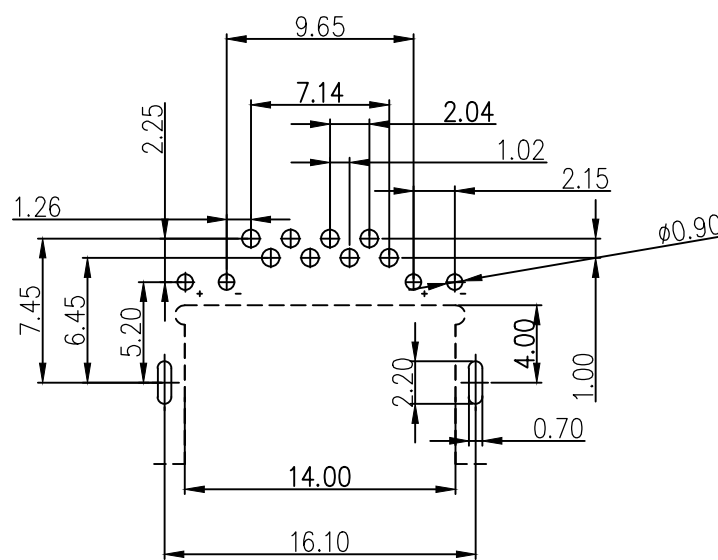
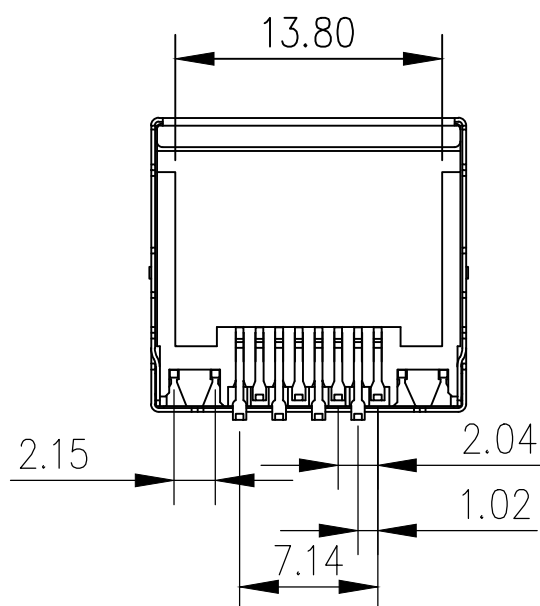

PCB参考图

	深圳市虹成电子有限公司		品名 TITLE	网口
			料号 PART NO	HC-WK88-C42-DK
UNLESS OTHERWISE, GENERAL TOLERANCE:		比列 SCALE	1:1	
X. xxx	±0.10	单位 UNIT	MM	制图 DRAW
X. xx	±0.20	张数 PART NO	1 OF 1	审核 CHECKED
X. x	±0.30	版本 REV	A	批准 APPROVE
ANGULAR:				夏操云
X. xx°	±1°			赵亮亮
X. x°	±3°			
X. °	±5°			

