

标记 MARK	ECN编号/变更内容 ECN NO/DEFINITION	修改 REVISE	日期 DATE	核准 APPROVE

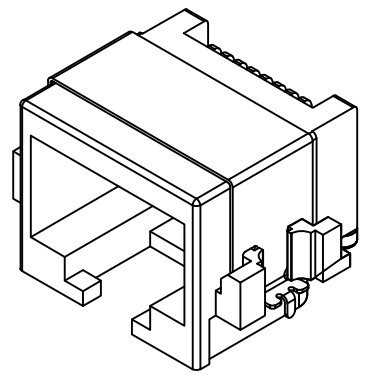

3D VIEW

- NOTES:
- MATERIAL:
 - HOUSING: LCP ,COLOR IS BLACK;
 - CONTACT: PHOSPHOR COPPER (C5191 T=0.30mm);
 - SHIELD: STAINLESS STEEL (304 T=0.2mm);
 - FINISH:
 - CONTACT: PLATED OVER NI,GOLD PLATED G/Fu";
 - SHELL: PLATED OVER NI;
 - ELECTRICAL:
 - VOLTAGE RATING: 125 VAC RMS;
 - CURRENT RATING: 1.5 AMP;
 - CONTACT RESISTANCE: 35MILLIOHMS MAX.;
 - WITHSTAND VOLTAGE: 500 VAC RMS 50(60)Hz,1MIN.;
 - INSULATION RESISTANCE: 500MEGOHMS MIN @500V DC.;
 - MECHANICAL:
 - MATING/UNMATING FORCE: 22N MAX.;
 - RETENTIION STRENGTH: 50N MIN.;
 - OPERATING LIFE: 750 CYCLES MIN.;
 - ENVIRONMENTAL:
 - STORAGE TEMPERATURE RANGE: -40°C~+85°C;
 - OPERATION TEMPERATURE RANGE: -25°C~+70°C;
 - SALT SPRAY TEST: 8H(EXCLUDING RIVETED BENDS)

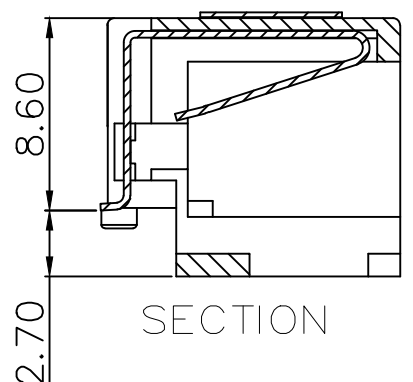
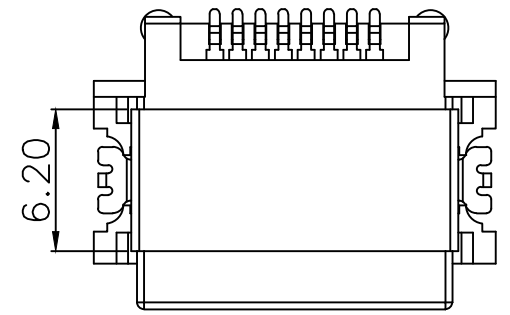
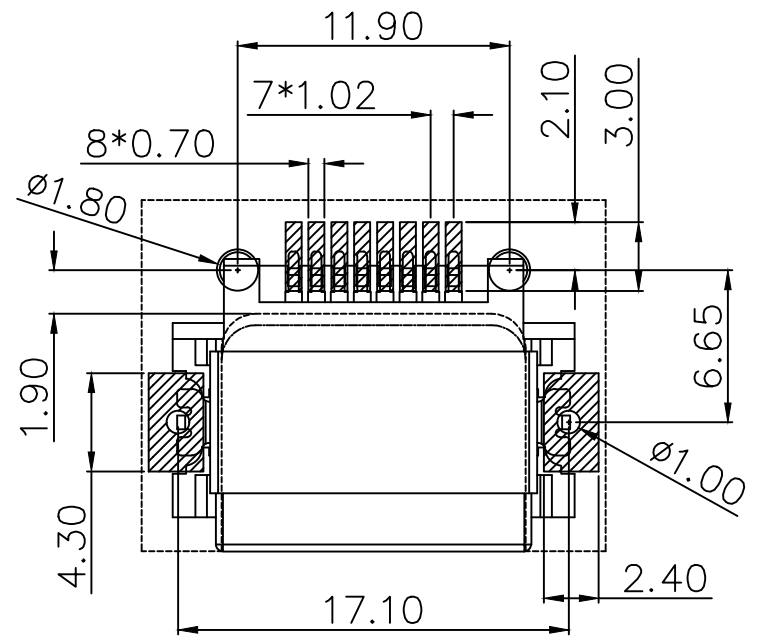
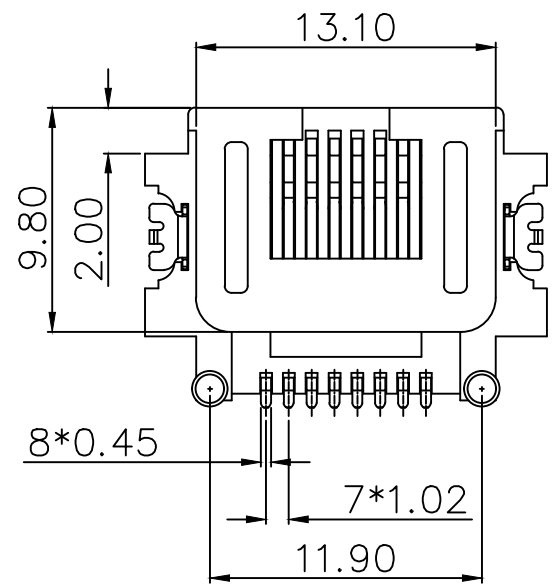
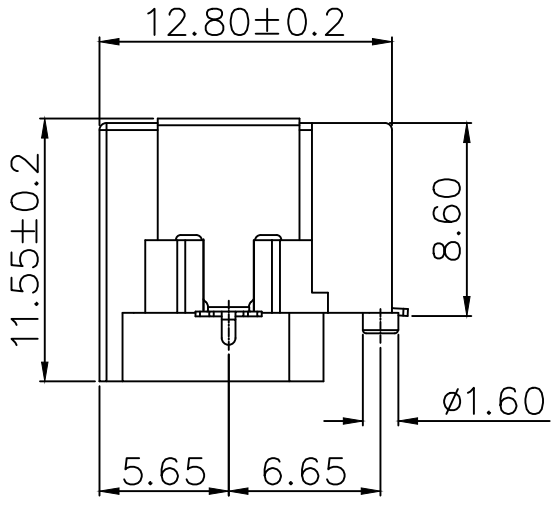
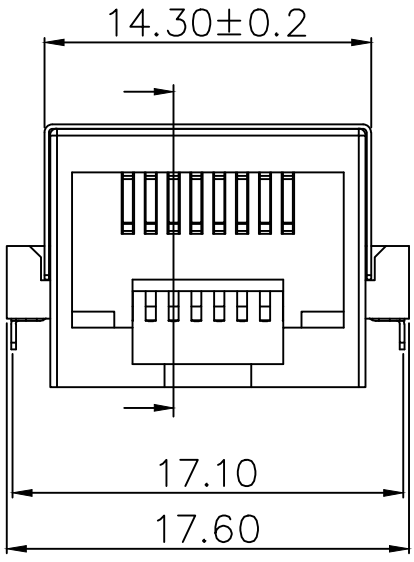

▨ PAD AREA (TOP VIEW)

3	外壳	不锈钢	镀镍	
2	接触	铜	镀金G/F	
1	基座	LCP	黑色	
序号	品名	材质	电镀/颜色	备注

	深圳市虹成电子有限公司 品名 TITLE: 网口 料号 PART NO: HC-WK88-H865T-BB		
	UNLESS OTHERWISE, GENERAL TOLERANCE: X. xxx ±0.10 X. xx ±0.20 X. x ±0.30 ANGULAR: X. xx° ±1° X. x° ±3° X. ° ±5°	比列 SCALE: 1:1 单位 UNIT: MM 张数 PART NO: 1 OF 1 版本 REV: A	

