

| | | | | |
|------------|---------------------------------|--------------|------------|---------------|
| 标记 MARK | ECN编号/变更内容 ECN NO/DEFINITION | 修改 REVISE | 日期 DATE | 核准 APPROVE |
| | | | | |

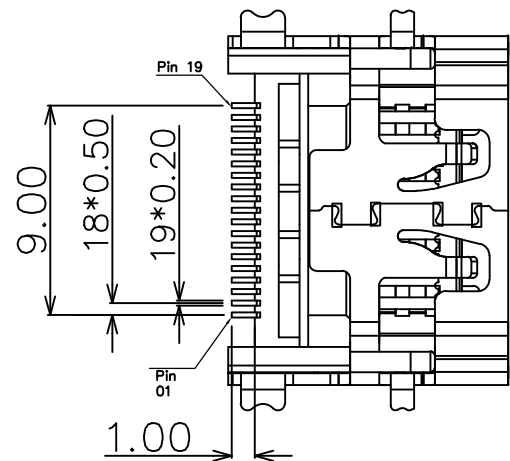
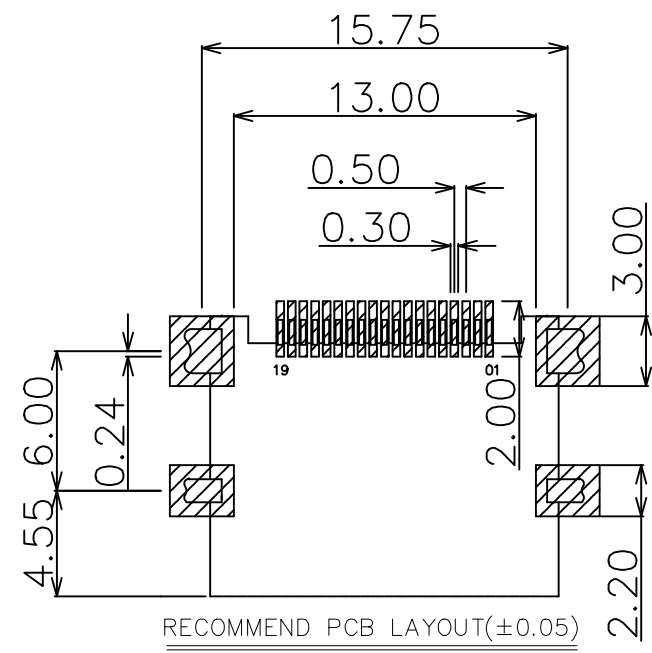
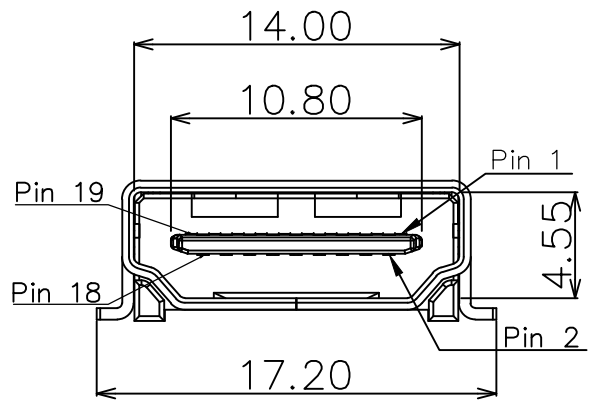
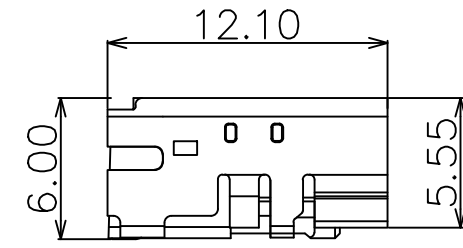
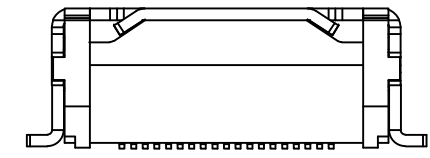
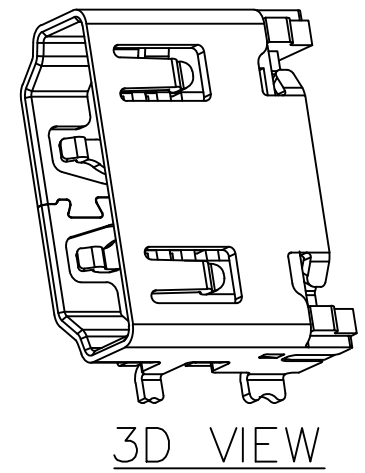
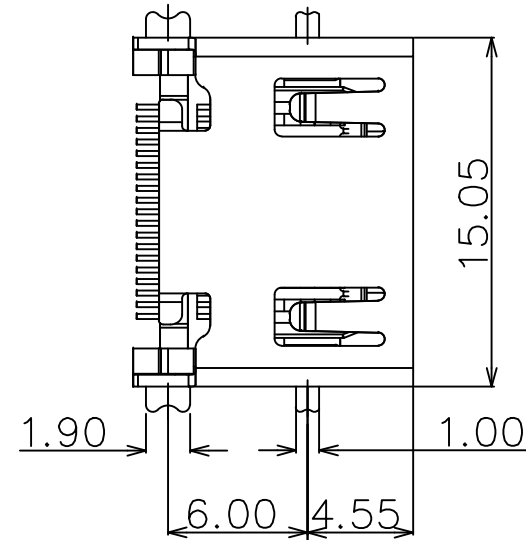

NOTES

- 1. MATERIAL:
 - 1.1. HOUSING: LCP,COLOR IS GRAY,HIGH TEMPERATURE PLASTIC;
 - 1.2. CONTACT: BRASS(H65 T=0.20mm);
 - 1.3. SHELL: COLD ROLLED IRON(SPCC,T=0.5mm);
- 2. FINISH:
 - 2.1. TERMINAL:
 - CONTACT AREA: GOLD PLATED G/Fu";
 - SOLDER AREA: PLATED OVER TIN;
 - 2.2. SHELL: NI PLATED OVER ALL ;
- 4. ELECTRICAL:
 - 4.1. VOLTAGE RATING: 40 VAC RMS;
 - 4.2. CURRENT RATING: 0.5 AMP;
 - 4.3. CONTACT RESISTANCE: 30mΩ MAX.;
 - 4.4. WITHSTAND VOLTAGE: 500 VAC RMS
50(60)Hz,1MIN.;
 - 4.5. INSULATION RESISTANCE: 100MEGOHMS MIN
@500V DC;
- 5. MECHANICAL:
 - 5.1. MATING FORCE: 44.1N MAX.;
 - 5.2. UNMATING FORCE: 9.8N MIN.;
 - 5.3. OPERATING LIFE: 10000 CYCLES MIN.;
- 6. ENVIRONMENTAL:
 - 6.1. STORAGE TEMPERATURE RANGE: -40°C~+85°C
 - 6.2. OPERATION TEMPERATURE RANGE: -25°C~+70°C;
- 7.SALT SPRAY TEST:24H(Salt spray test 24hours for gold plated area and 8 hours for tin plated area)

| 3 | 外壳 | 铁 | 镀镍 | |
|----|----|-----|-------|----|
| 2 | 接触 | 铜 | 镀金 | |
| 1 | 基座 | LCP | 灰色 | |
| 序号 | 品名 | 材质 | 电镀/颜色 | 备注 |

| | | | | | |
|----------------|-----------------------|---------------|---------------|----------------|------|
| | 深圳市虹成电子有限公司 | | 品名 TITLE | HDMI座 | |
| | | | 料号 PART NO | HC-HDMI0019T-4 | |
| UNLESS GENERAL | OTHERWISE, TOLERANCE: | 比列 SCALE | 1:1 | | |
| X.xxx ±0.10 | | 单位 UNIT | MM | | |
| X.xx ±0.20 | | 张数 PART NO | 1 OF 1 | 制图 DRAW | AhYe |
| X.x ±0.30 | | 版本 REV | A | 审核 CHECKED | 夏操云 |
| ANGULAR: | | | | 批准 APPROVE | 赵亮亮 |
| X.xx° ±1° | | | | | |
| X.x° ±3° | | | | | |
| X° ±5° | | | | | |