

标记 MARK	ECN编号/变更内容 ECN NO/DEFINITION	修改 REVISE	日期 DATE	核准 APPROVE

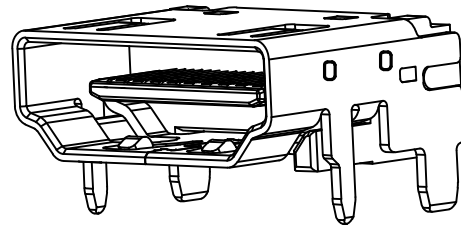
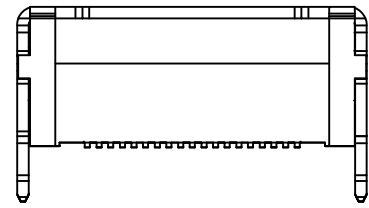
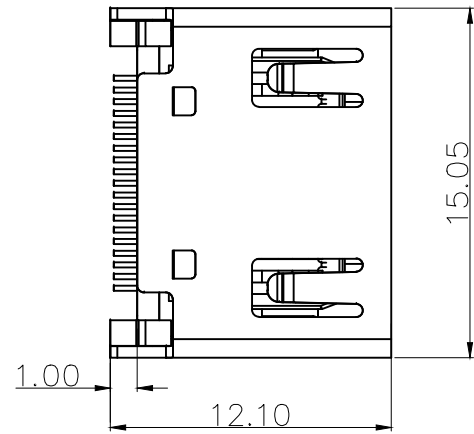

3D VIEW

NOTES

1. MATERIAL:
 - 1.1. HOUSING: LCP,COLOR IS GRAY,HIGH TEMPERATURE PLASTIC;
 - 1.2. CONTACT: BRASS(H65 T=0.20mm);
 - 1.3. SHELL: COLD ROLLED IRON(SPCC,T=0.50mm);
2. FINISH:
 - 2.1. TERMINAL:
CONTACT AREA: GOLD PLATED G/Fu";
SOLDER AREA: PLATED OVER TIN;
 - 2.2. SHELL: NI PLATED OVER ALL ;
4. ELECTRICAL:
 - 4.1. VOLTAGE RATING: 40 VAC RMS;
 - 4.2. CURRENT RATING: 0.5 AMP;
 - 4.3. CONTACT RESISTANCE: 30mΩ MAX.;
 - 4.4. WITHSTAND VOLTAGE: 500 VAC RMS
50(60)Hz,1MIN.;
 - 4.5. INSULATION RESISTANCE: 100MEGOHMS MIN
@500V DC;
5. MECHANICAL:
 - 5.1. MATING FORCE: 44.1N MAX.;
 - 5.2. UNMATING FORCE: 9.8N MIN.;
 - 5.3. OPERATING LIFE: 10000 CYCLES MIN.;
6. ENVIRONMENTAL:
 - 6.1. STORAGE TEMPERATURE RANGE: -40°C~+85°C
 - 6.2. OPERATION TEMPERATURE RANGE: -25°C~+70°C;
- 7.SALT SPRAY TEST:24H(Salt spray test 24hours for gold plated area and 8 hours for tin plated area)

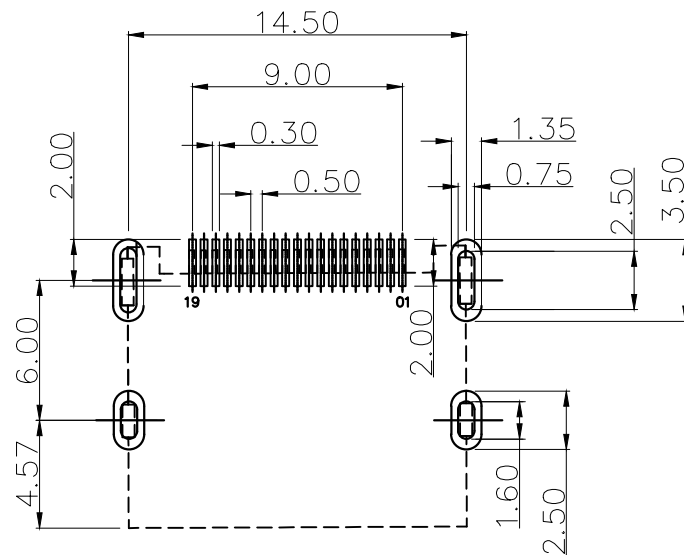
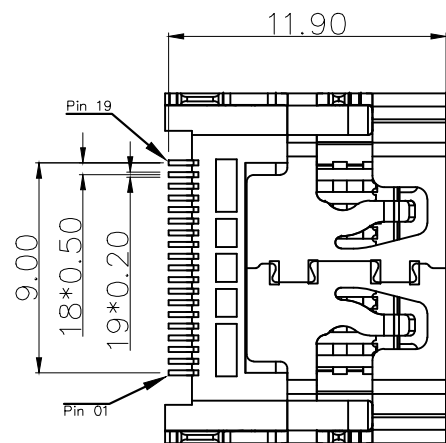
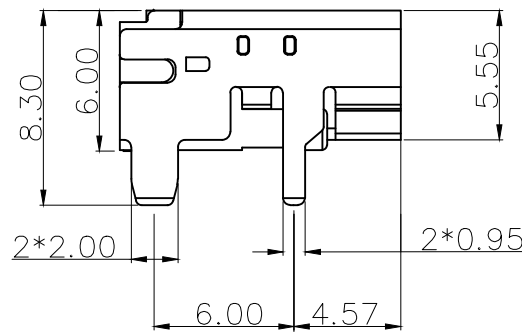
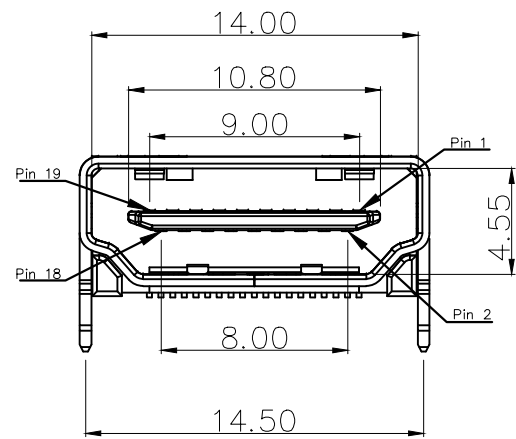

RECOMMEND PCB LAYOUT(±0.05)

3	外壳	铁	镀镍	
2	接触	铜	镀金	
1	基座	LCP	灰色	
序号	品名	材质	电镀/颜色	备注

	深圳市虹成电子有限公司 TITLE 品名 HDMI座		料号 PART NO HC-HDMI0019T-1	
	UNLESS OTHERWISE, GENERAL TOLERANCE: X.xxx ±0.10 X.xx ±0.20 X.x ±0.30 X. ±0.35 ANGULAR: X.xx' ±1' X.x' ±3' X.' ±5'	比列 SCALE 1:1	单位 UNIT MM	制图 DRAW AhYe
张数 PART NO 1 OF 1	版本 REV A	审核 CHECKED 夏操云	批准 APPROVE 赵亮亮	