

A

B

C

D

E

F

G

A

B

C

D

E

F

G

PIN NUMBER	SIGNAL NAME
PIN 1	Vbus
PIN 2	D-
PIN 3	D+
PIN 4	GND
PIN 5	StdA_SSRX-
PIN 6	StdA_SSRX+
PIN 7	GND_DRAIN
PIN 8	StdA_SSTX-
PIN 9	StdA_SSTX+
SHELL	GND

标记 MARK	ECN编号/变更内容 ECN NO/DEFINITION	修改 REVISE	日期 DATE	核准 APPROVE

NOTES

- MATERIAL:
 - HOUSING: LCP ,COLOR IS BLUE;
 - CONTACT: BRASS, (H65 T=0.20mm);
 - SHELL: COLD ROLLED IRON (SPCC,T=0.3mm);
- FINISH:
 - TERMINAL:
 - CONTACT AREA: GOLD PLATED G/Fu";
 - SOLDER AREA: PLATED OVER TIN;
 - SHELL: NI PLATED OVER ALL ;
- ELECTRICAL:
 - VOLTAGE RATING: 30 VAC RMS;
 - CURRENT RATING: 1.5 AMP;
 - CONTACT RESISTANCE: 30MILLIOHMS MAX.;
 - WITHSTAND VOLTAGE: 500 VAC RMS
50(60)Hz,1MIN.;
 - INSULATION RESISTANCE: 100MEGOHMS MIN
@500V DC;
- MECHANICAL:
 - MATING FORCE: 35N MAX.;
 - UNMATING FORCE: 5~35N;
 - OPERATING LIFE: 1500 CYCLES MIN.;
- ENVIRONMENTAL:
 - STORAGE TEMPERATURE RANGE: -40°C~+85°C
 - OPERATION TEMPERATURE RANGE: -25°C~+70°C;
- SALT SPRAY TEST: 24H(EXCLUDING RIVETED BENDS)

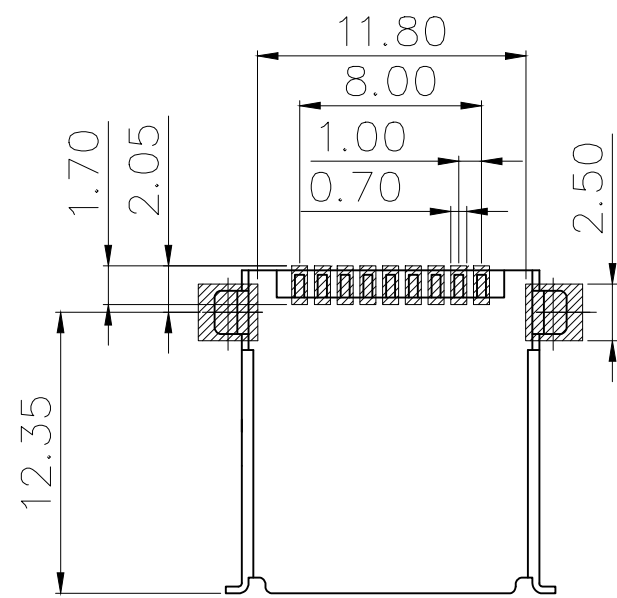
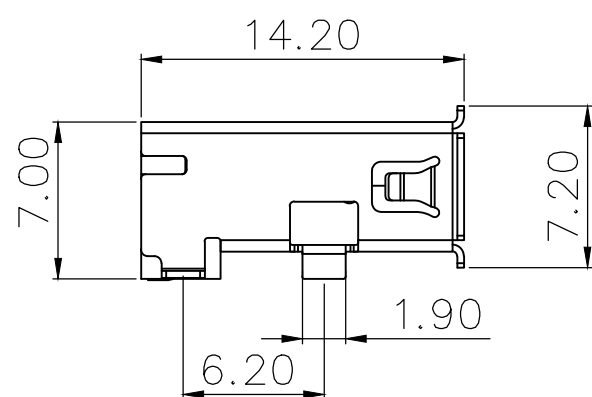
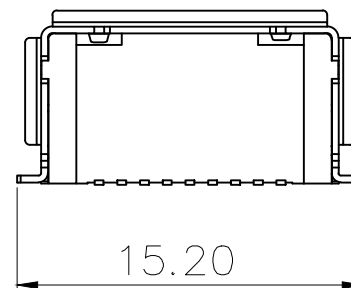
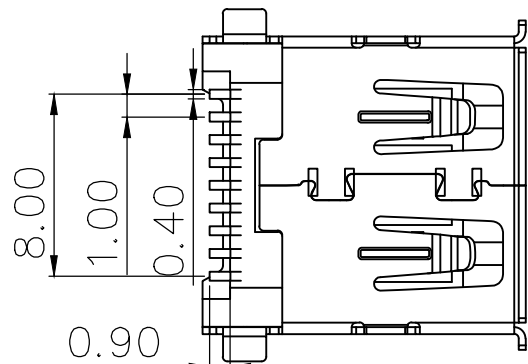
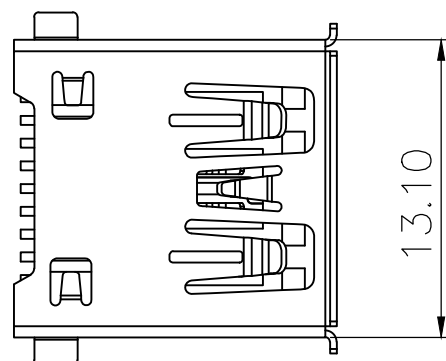
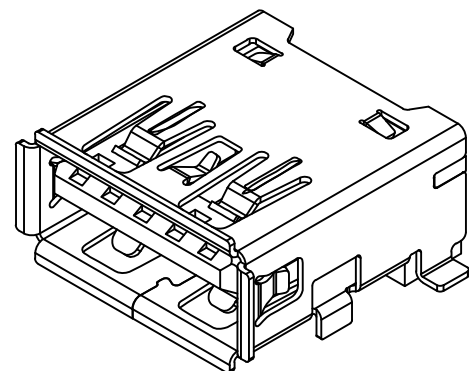
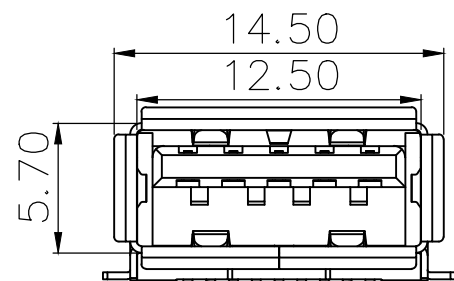

RECOMMEND PCB LAYOUT(±0.05)

3	外壳	铁	镀镍	
2	接触	铜	镀金	
1	基座	LCP	蓝色	
序号	品名	材质	电镀/颜色	备注

	深圳市虹成电子有限公司		品名 TITLE	USB座	
			料号 PART NO	HC-USB3.0-L142-J	
UNLESS OTHERWISE, GENERAL TOLERANCE:		比列 SCALE	1:1		
X.xxx ±0.10		单位 UNIT	MM	制图 DRAW	AhYe
X.xx ±0.20		张数 PART NO	1 OF 1	审核 CHECKED	夏操云
X.x ±0.30		版本 REV	A	批准 APPROVE	赵亮亮
ANGULAR: X.xx° ±1° X.x° ±3° X.° ±5°					