

A

B

C

D

E

F

G

A

B

C

D

E

F

G

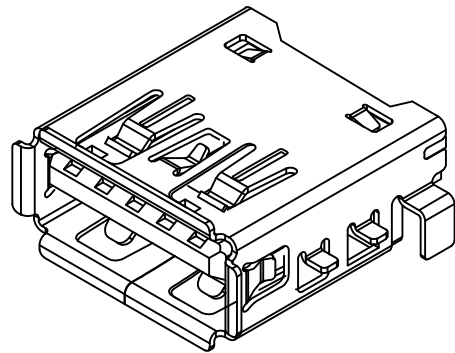
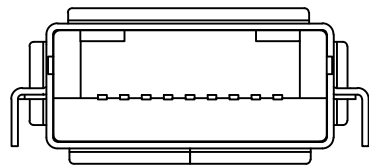

3D VIEW

PIN NUMBER	SIGNAL NAME
PIN 1	Vbus
PIN 2	D-
PIN 3	D+
PIN 4	GND
PIN 5	StdA_SSRX-
PIN 6	StdA_SSRX+
PIN 7	GND_DRAIN
PIN 8	StdA_SSTX-
PIN 9	StdA_SSTX+
SHELL	GND

标记 MARK	ECN编号/变更内容 ECN NO/DEFINITION	修改 REVISE	日期 DATE	核准 APPROVE

NOTES

- MATERIAL:
 - HOUSING: LCP ,COLOR IS BLUE,HIGH TEMPERATURE PLASTIC;
 - CONTACT: BRASS (H65 T=0.20mm);
 - SHELL: COLD ROLLED IRON (SPCC T=0.30mm);
- ELECTRICAL:
 - VOLTAGE RATING: 30V DC ;
 - CURRENT RATING: 1.5A ;
 - CONTACT RESISTANCE: 30MILLIOHMS MAX.;
 - WITHSTAND VOLTAGE: 100V AC RMS 50(60)Hz,1MIN.;
 - INSULATION RESISTANCE: 100MEGOHMS MIN @500V DC;
- MECHANICAL:
 - MATING FORCE: 35N MAX.;
 - UNMATING FORCE: 5~35N ;
 - OPERATING LIFE: 1500 CYCLES MIN.;
- PLATING:
 - TERMINAL:
 - NI PLATING OVER ALL,
 - Tin PLATING ON SOLDER AREA,
 - Au G/Fu" ON CONTACT AREA;
 - SHELL: NI PLATING OVER ALL;
- ENVIRONMENTAL:
 - STORAGE TEMPERATURE RANGE: -40°C~+85°C
 - OPERATION TEMPERATURE RANGE: -25°C~+70°C;
 - SALT SPRAY TEST:24H(EXCLUDING RIVETED BENDS)

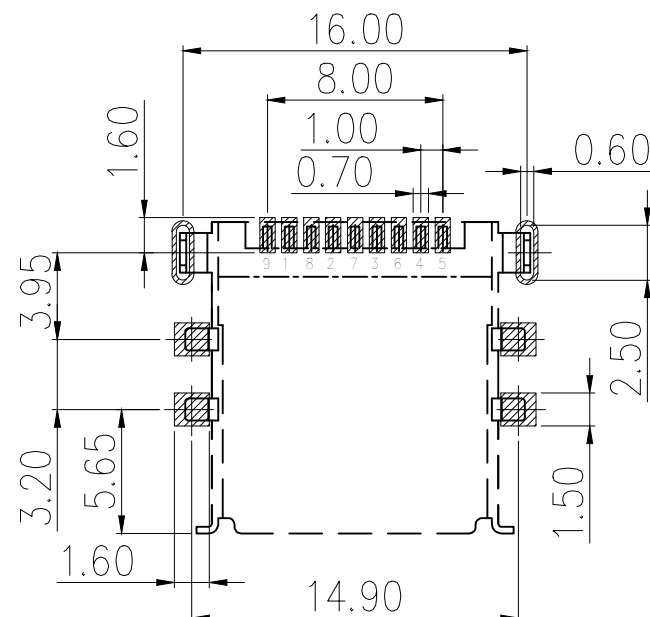
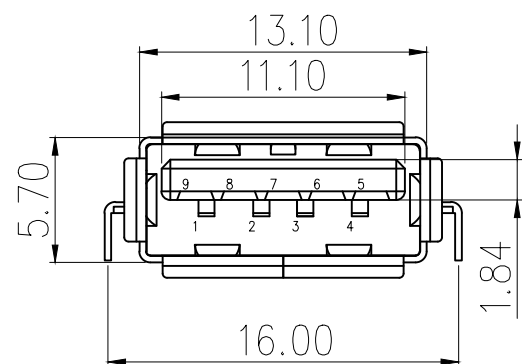
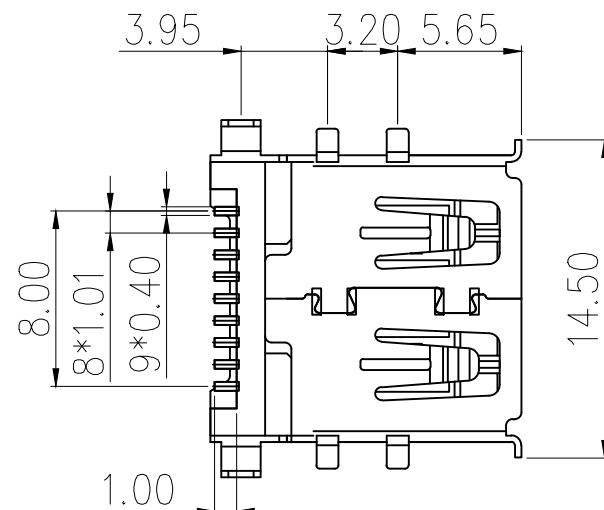
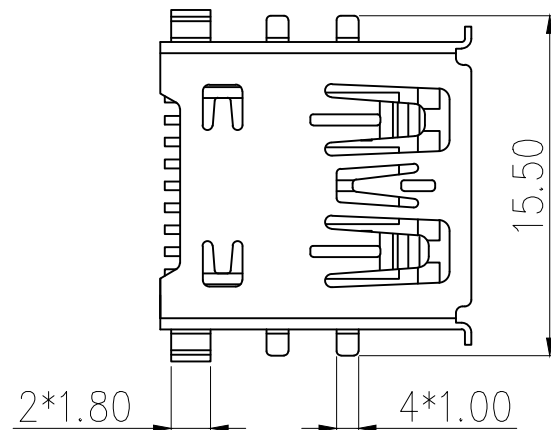

RECOMMEND PCB LAYOUT(±0.05)

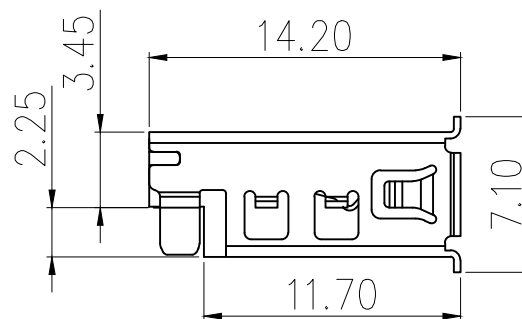

3	外壳	铁	镀镍	
2	接触	铜	镀金	
1	基座	LCP	蓝色	
序号	品名	材质	电镀/颜色	备注

	深圳市虹成电子有限公司 TITLE USB座		品名 料号 HC-USB3.0-C225-J PART NO	
	UNLESS OTHERWISE, GENERAL TOLERANCE: X.xxx ±0.10 X.xx ±0.20 X.x ±0.30 ANGULAR: X.xx° ±1° X.x° ±3° X.° ±5°	比列 SCALE 1:1	单位 UNIT MM	制图 DRAW AhYe
张数 PART NO 1 OF 1	版本 REV A	审核 CHECKED 夏操云	批准 APPROVE 赵亮亮	