

PIN NUMBER	SIGNAL NAME
PIN 1	Vbus
PIN 2	D-
PIN 3	D+
PIN 4	GND
PIN 5	StdA_SSRX-
PIN 6	StdA_SSRX+
PIN 7	GND_DRAIN
PIN 8	StdA_SSTX-
PIN 9	StdA_SSTX+
SHELL	GND

标记 MARK	ECN编号/变更内容 ECN NO/DEFINITION	修改 REVISE	日期 DATE	核准 APPROVE

NOTES:

- MATERIAL:
 - HOUSING: LCP ,COLOR IS BLUE,HIGH TEMPERATURE PLASTIC;
 - CONTACT: BRASS (H65 T=0.20&0.25mm);
 - SHELL: COLD ROLLED IRON (SPCC T=0.30mm);
- ELECTRICAL:
 - VOLTAGE RATING: 30V DC ;
 - CURRENT RATING: 1.5A ;
 - CONTACT RESISTANCE: 30MILLIOHMS MAX.;
 - WITHSTAND VOLTAGE: 100 VAC RMS 50(60)Hz,1MIN.;
 - INSULATION RESISTANCE: 100MEGOHMS MIN @500V DC;
- MECHANICAL:
 - MATING FORCE: 35N MAX.;
 - UNMATING FORCE: 5~35N ;
 - OPERATING LIFE: 1500 CYCLES MIN.;
- PLATING:
 - TERMINAL:
 - NI PLATING OVER ALL,
 - Tin PLATING ON SOLDER AREA,
 - Au 1U" ON CONTACT AREA;
 - SHELL: NI PLATING OVER ALL;
- ENVIRONMENTAL:
 - STORAGE TEMPERATURE RANGE: -40°C~+85°C;
 - OPERATION TEMPERATURE RANGE: -25°C~+70°C;
- SALT SPRAY TEST: 24H(EXCLUDING RIVETED BENDS)

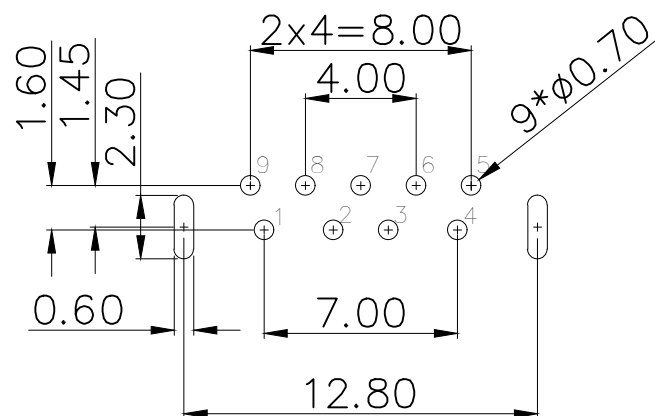
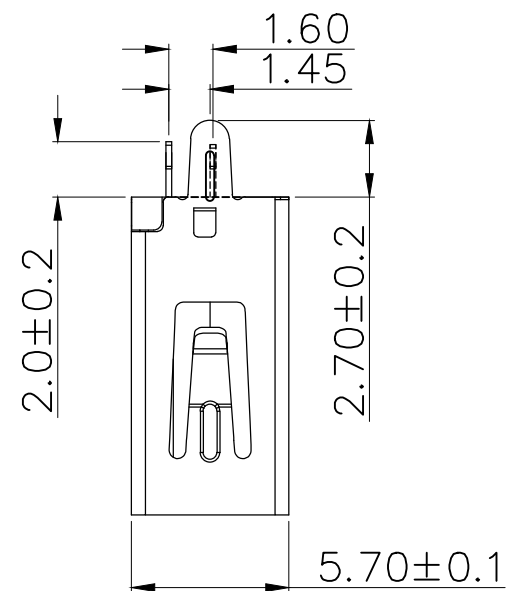
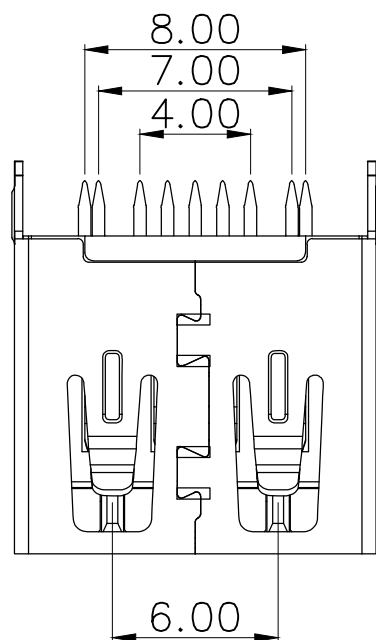
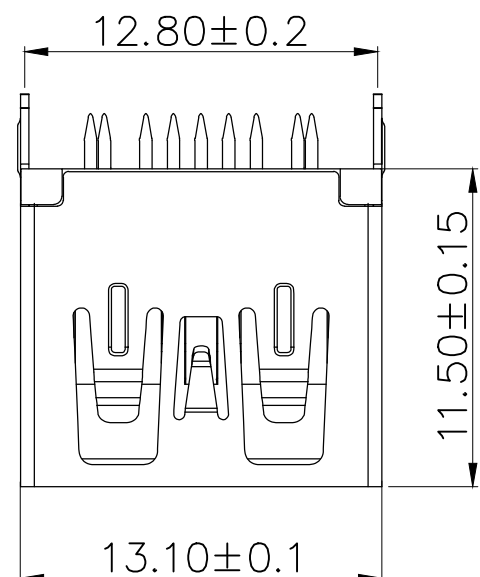

RECOMMENDER P.C.B. LAYOUT TOP VIEW (COMPONENT SIDE TOLERANCE±0.05)

3	外壳	铁	镀镍	
2	接触	铜	镀金	
1	基座	LCP	蓝色	
序号	品名	材质	电镀/颜色	备注

	深圳市虹成电子有限公司		品名 TITLE	USB座	
			料号 PART NO	HC-USB3.0-L115-ZP	
UNLESS OTHERWISE, GENERAL TOLERANCE:		比列 SCALE	1:1		
X. xxx ±0.10 X. xx ±0.20 X. x ±0.30		单位 UNIT	MM		
ANGULAR: X. xx° ±1° X. x° ±3° X. ° ±5°		张数 PART NO	1 OF 1	制图 DRAW	AhYe
		版本 REV	A	审核 CHECKED	夏操云
				批准 APPROVE	赵亮亮

