

A

B

C

D

E

F

G

A

B

C

D

E

F

G

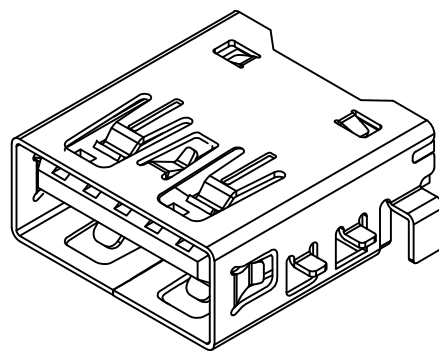
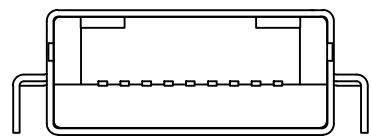

3D VIEW

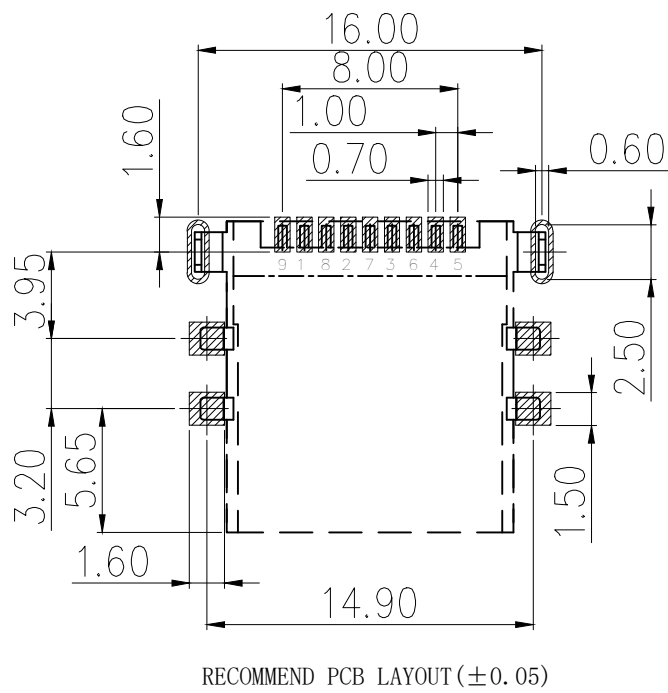
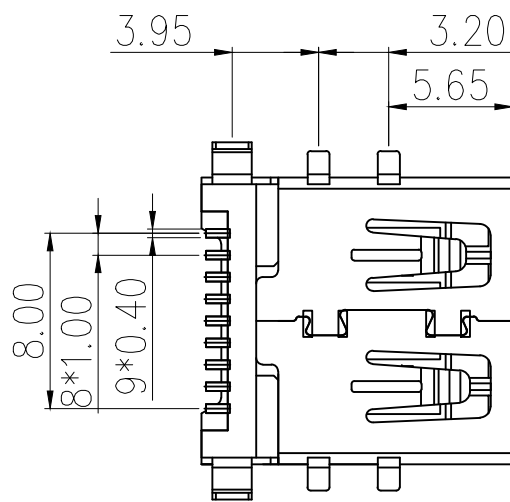
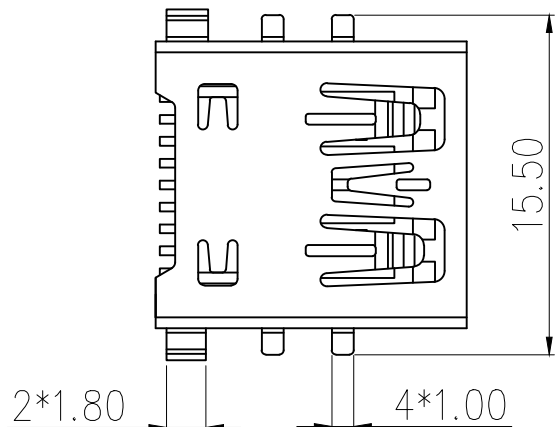
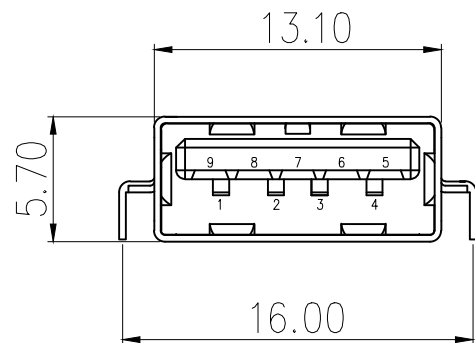

RECOMMEND PCB LAYOUT(±0.05)

PIN NUMBER	SIGNAL NAME
PIN 1	Vbus
PIN 2	D-
PIN 3	D+
PIN 4	GND
PIN 5	StdA_SSRX-
PIN 6	StdA_SSRX+
PIN 7	GND_DRAIN
PIN 8	StdA_SSTX-
PIN 9	StdA_SSTX+
SHELL	GND

标记 MARK	ECN编号/变更内容 ECN_NO/DEFINITION	修改 REVISE	日期 DATE	核准 APPROVE

NOTES:

- MATERIAL:
  - HOUSING: LCP ,COLOR IS BLUE,HIGH TEMPERATURE PLASTIC;
  - CONTACT: BRASS (H65 T=0.20mm);
  - SHELL: COLD ROLLED IRON (SPCC T=0.30mm);
- ELECTRICAL:
  - VOLTAGE RATING: 30V DC ;
  - CURRENT RATING: 1.5A ;
  - CONTACT RESISTANCE: 30MILLIOHMS MAX.;
  - WITHSTAND VOLTAGE: 100V AC RMS 50(60)Hz,1MIN.;
  - INSULATION RESISTANCE: 100MEGOHMS MIN @500V DC;
- MECHANICAL:
  - MATING FORCE: 35N MAX.;
  - UNMATING FORCE: 5~35N ;
  - OPERATING LIFE: 1500 CYCLES MIN.;
- PLATING:
  - TERMINAL:
    - NI PLATING OVER ALL,
    - Tin PLATING ON SOLDER AREA,
    - Au G/Fu" ON CONTACT AREA;
  - SHELL: NI PLATING OVER ALL;
- ENVIRONMENTAL:
  - STORAGE TEMPERATURE RANGE: -40°C~+85°C ;
  - OPERATION TEMPERATURE RANGE: -25°C~+70°C;
- SALT SPRAY TEST: 24H(EXCLUDING RIVETED BENDS)

3	外壳	铁	镀镍	
2	接触	铜	镀金	
1	基座	LCP	蓝色	
序号	品名	材质	电镀/颜色	备注

	深圳市虹成电子有限公司		品名 TITLE	USB座	
			料号 PART NO	HC-USB3.0-C225-P	
UNLESS OTHERWISE, GENERAL TOLERANCE:		比列 SCALE	1:1		
X.xxx ±0.10		单位 UNIT	MM		
X.xx ±0.20		张数 PART NO	1 OF 1	制图 DRAW	AhYe
X.x ±0.30		版本 REV	A	审核 CHECKED	夏操云
ANGULAR:		批准 APPROVE	赵亮亮		
X.xx° ±1°					
X.x° ±3°					
X.° ±5°					