

| 标记 MARK | ECN编号/变更内容 ECN NO/DEFINITION | 修改 REVISE | 日期 DATE | 核准 APPROVE |
|------------|---------------------------------|--------------|------------|---------------|
| | | | | |

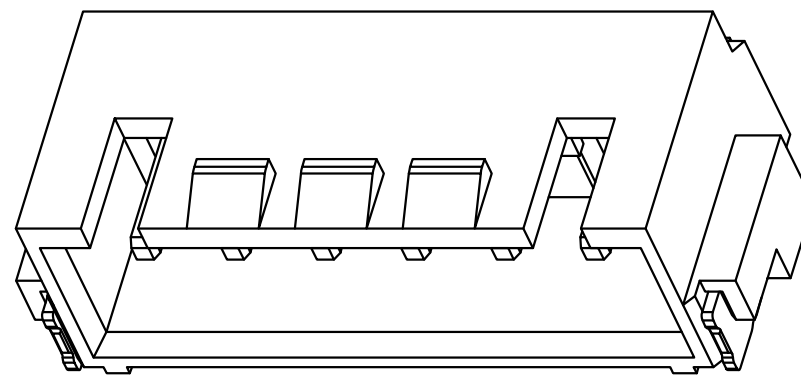

| CKI | DIM A | DIM B | DIM C |
|-----|-------|-------|-------|
| 2 | 2.50 | 7.50 | 10.00 |
| 3 | 5.00 | 10.00 | 12.50 |
| 4 | 7.50 | 12.50 | 15.00 |
| 5 | 10.00 | 15.00 | 17.50 |
| 6 | 12.50 | 17.50 | 20.00 |
| 7 | 15.00 | 20.00 | 22.50 |
| 8 | 17.50 | 22.50 | 25.00 |
| 9 | 20.00 | 25.00 | 27.50 |
| 10 | 22.50 | 27.50 | 30.00 |
| 11 | 25.00 | 30.00 | 32.50 |
| 12 | 27.50 | 32.50 | 35.00 |
| 13 | 30.00 | 35.00 | 37.50 |
| 14 | 32.50 | 37.50 | 40.00 |
| 15 | 35.00 | 40.00 | 42.50 |
| 16 | 37.50 | 42.50 | 45.00 |

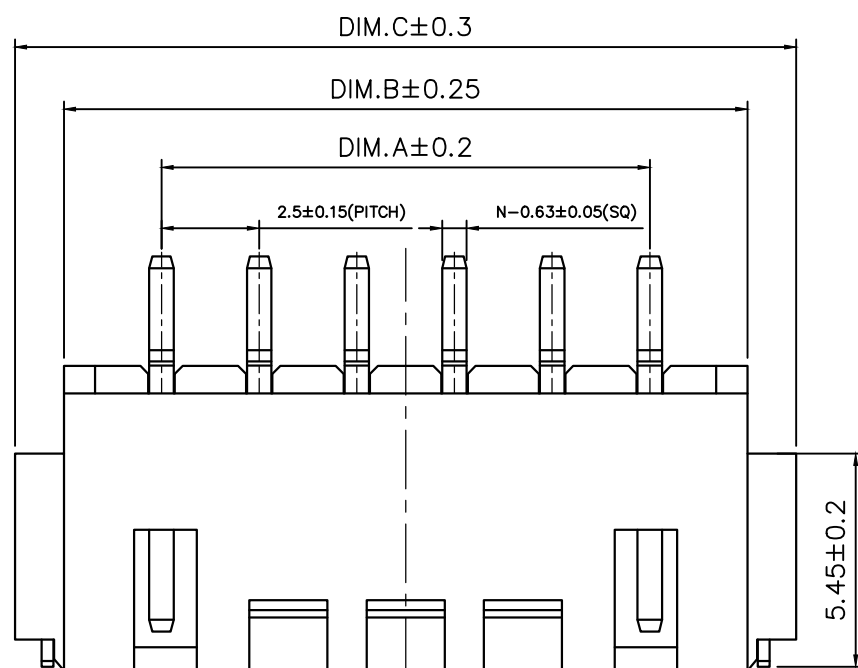
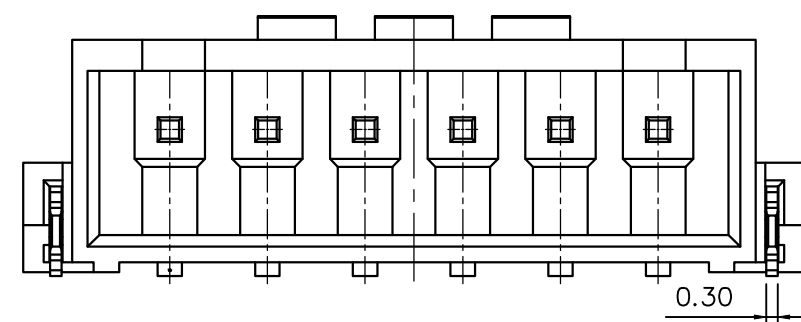

技术指标:

1. 工作温度: -25°C~85°C
2. 额定电压: 250V, DC/AC(rms)
3. 额定电流: 3.0A
4. 接触电阻: ≤20mΩ
5. 耐压: 1000V AC/minute
6. 绝缘电阻: ≥1000MΩ
7. 适用线规: AWG#30~#22

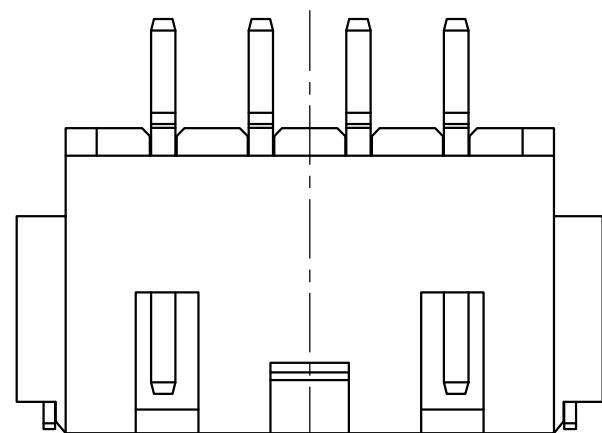
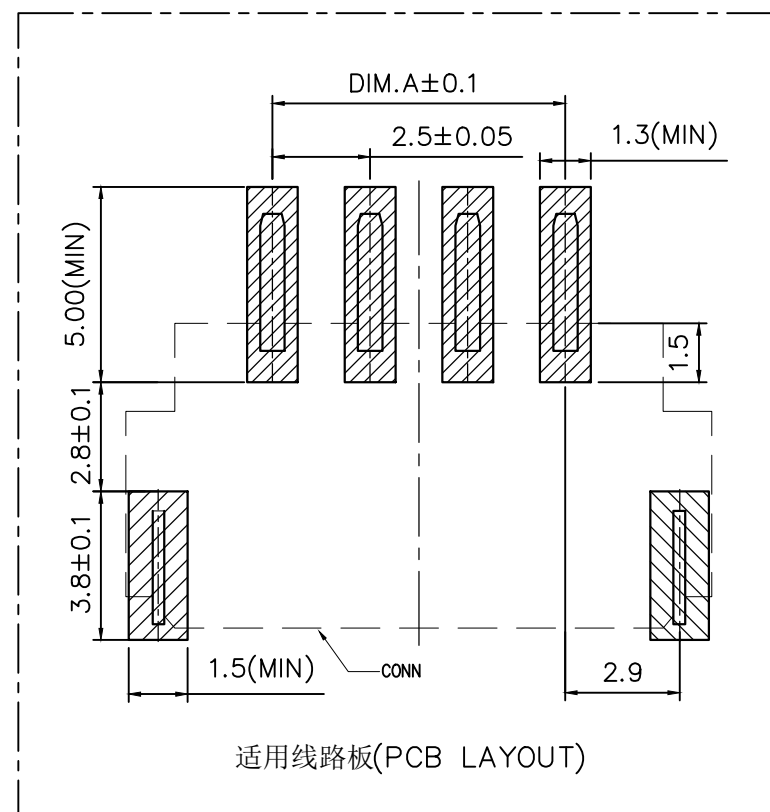
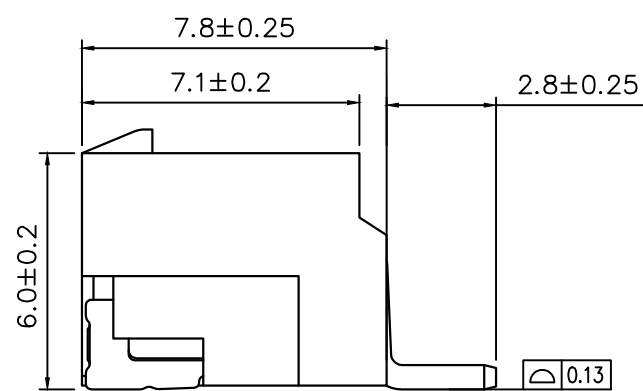

| 序号 | 品名 | 材质 | 电镀/颜色 | 备注 |
|----|----|-----|-------|----|
| 2 | 插针 | 铜 | 镀锡 | |
| 1 | 基座 | LCP | 本色 | |

 深圳市虹成电子有限公司

品名 TITLE: 针座
料号 PART NO: HCZZ0520-4

GENERAL TOLERANCES (UNLESS SPECIFIED): 比列 SCALE: 1:1

单位 UNIT: MM
张数 PART NO: 1 OF 1
版本 REV: A

制图 DRAW: AhYe
审核 CHECKED: 夏操云
批准 APPROVE: 赵亮亮

