

标记 MARK	ECN编号/变更内容 ECN NO/DEFINITION	修改 REVISE	日期 DATE	核准 APPROVE

Pin	A	B	C	D
2	1.25	3.85	5.80	0.50
3	2.50	5.10	7.05	1.75
4	3.75	6.35	8.30	2.00
5	5.00	7.60	9.55	3.26
6	6.25	8.85	10.80	4.52
7	7.50	10.10	12.05	4.50
8	8.75	11.35	13.30	4.50
9	10.00	12.60	14.55	4.50
10	11.25	13.85	15.80	6.50
11	12.50	15.10	17.05	6.50
12	13.75	16.35	18.30	6.50
13	15.00	17.60	19.55	6.50
14	16.25	18.85	20.80	6.50
15	17.50	20.10	22.05	6.50
16	18.75	21.35	23.30	6.50

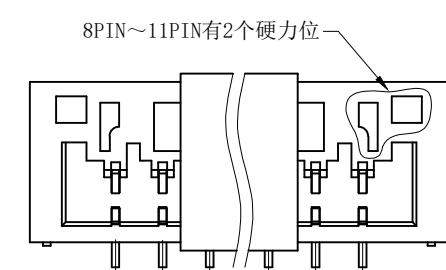

1. 技术参数:
- 1.1 额定电流: 1.0A AC/DC
  - 1.2 额定电压: 50V AC DC
  - 1.3 耐电压: 500V ACminute
  - 1.4 接触电阻: 20mΩ MAX
  - 1.5 绝缘电阻: 500MΩ MIN
  - 2.0 工作温度: -25℃ ~ +85℃

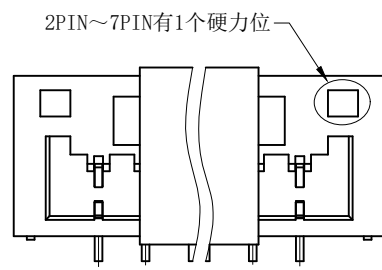
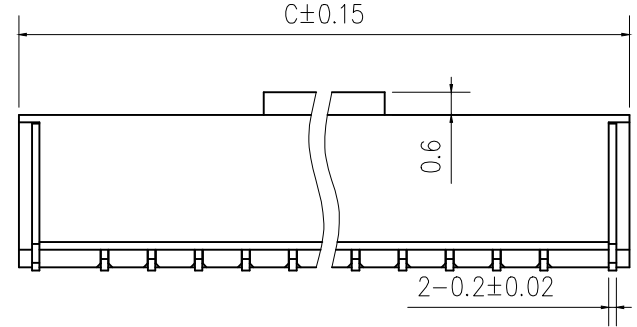
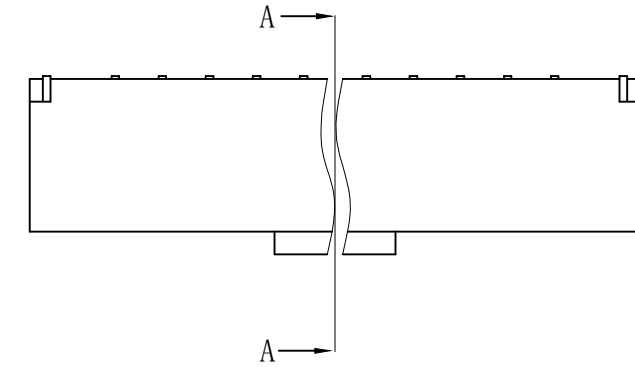
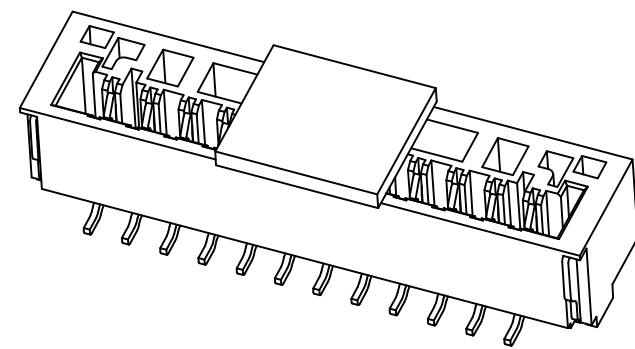
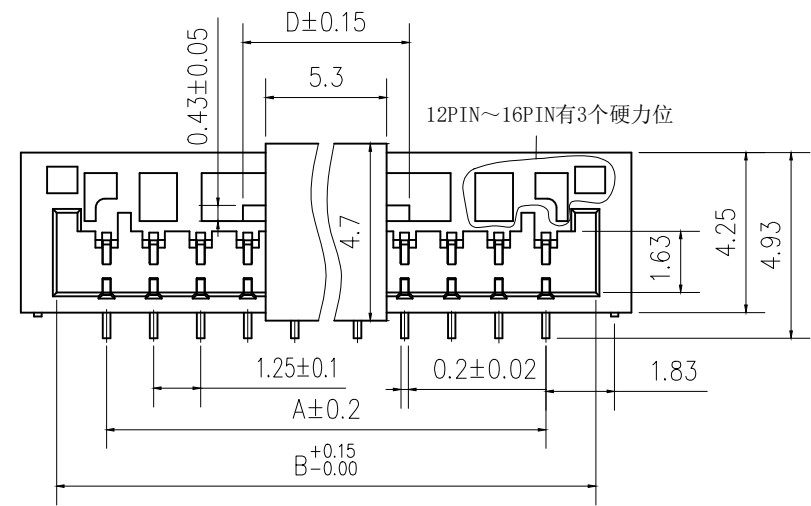
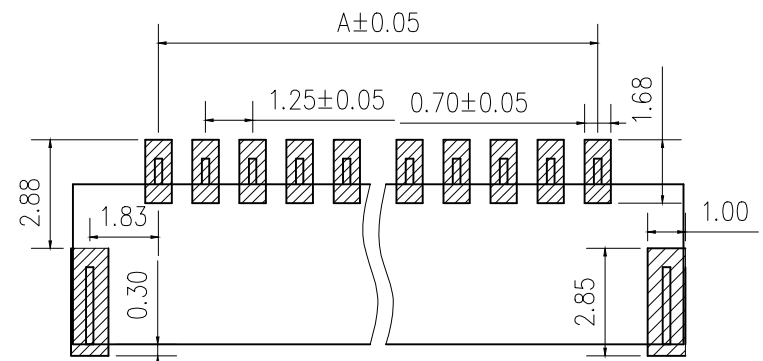
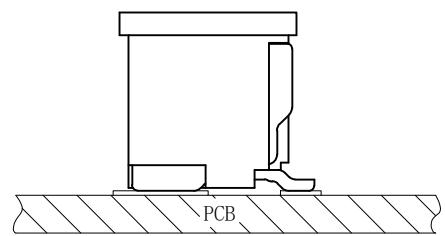
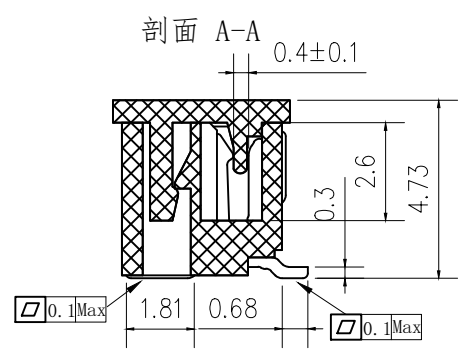

2	插针	铜	镀锡	
1	基座	LCP	本色	
序号	品名	材质	电镀/颜色	备注

**深圳市虹成电子有限公司**  
 品名 TITLE: 针座  
 料号 PART NO: HCZZ0494-2  
 比例 SCALE: 1:1  
 制图 DRAW: AhYe  
 审核 CHECKED: 夏操云  
 批准 APPROVE: 赵亮亮  
 一般公差 (UNLESS SPECIFIED):  
 X.X ±0.30  
 X.XX ±0.20  
 X.XXX ±0.10  
 Angle ±3.0°  
 单位 UNIT: MM  
 张数 PART NO: 1 OF 1  
 版本 REV: A

