

标记 MARK	ECN编号/变更内容 ECN NO./DEFINITION	修改 REVISE	日期 DATE	核准 APPROVE

Pin	A	B	C	D
2	1.25	3.85	5.80	0.50
3	2.50	5.10	7.05	1.75
4	3.75	6.35	8.30	2.00
5	5.00	7.60	9.55	3.26
6	6.25	8.85	10.80	4.52
7	7.50	10.10	12.05	4.50
8	8.75	11.35	13.30	4.50
9	10.00	12.60	14.55	4.50
10	11.25	13.85	15.80	6.50
11	12.50	15.10	17.05	6.50
12	13.75	16.35	18.30	6.50
13	15.00	17.60	19.55	6.50
14	16.25	18.85	20.80	6.50
15	17.50	20.10	22.05	6.50
16	18.75	21.35	23.30	6.50

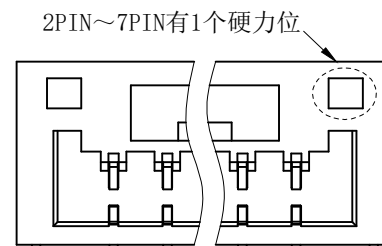
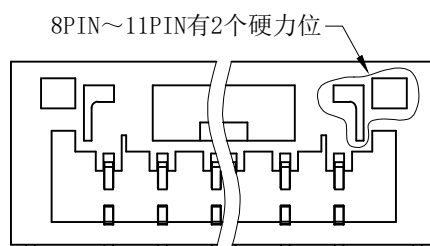
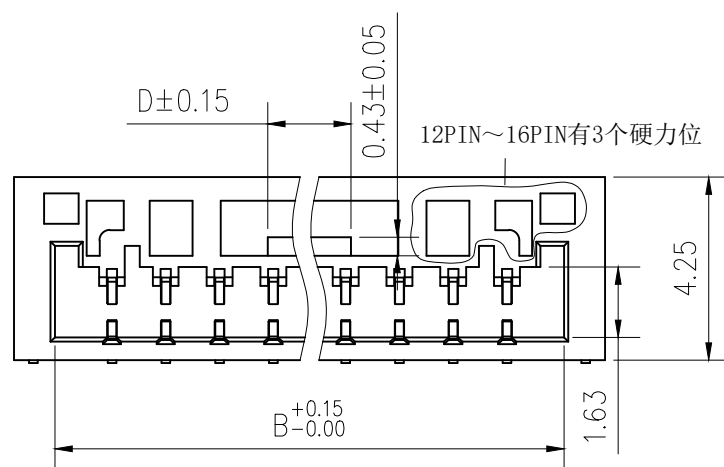
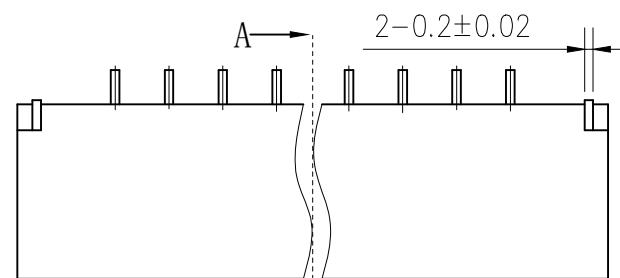
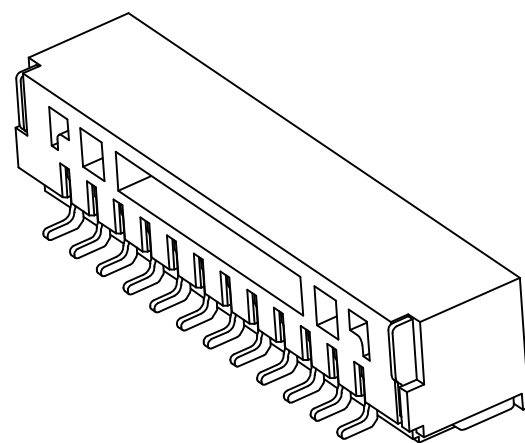
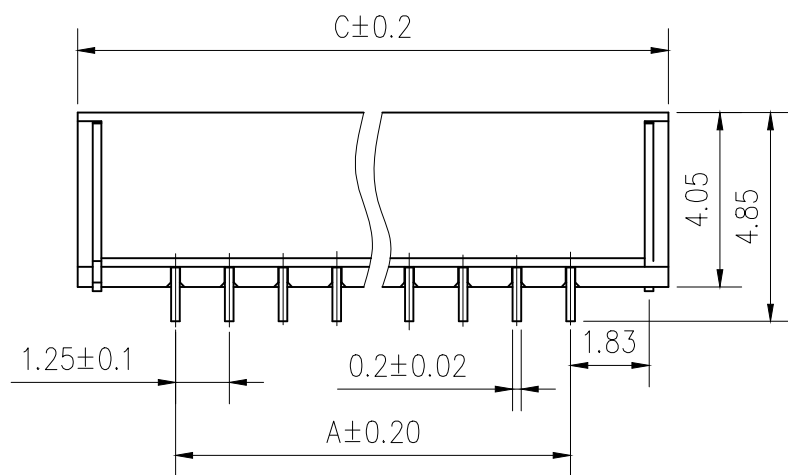

1. 技术参数:

- 1.1 额定电流: 1.0A AC/DC
- 1.2 额定电压: 125V
- 1.3 耐电压: 500V ACminute
- 1.4 接触电阻: 20mΩ MAX
- 1.5 绝缘电阻: 500MΩ MIN
- 2.0 工作温度: -25℃~+85℃

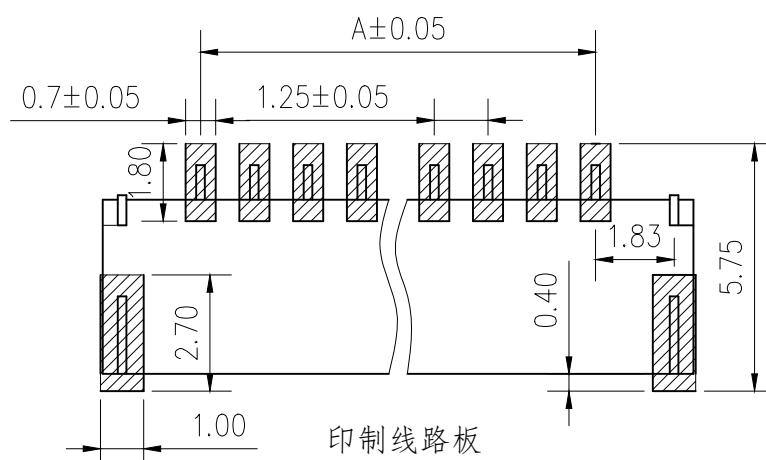
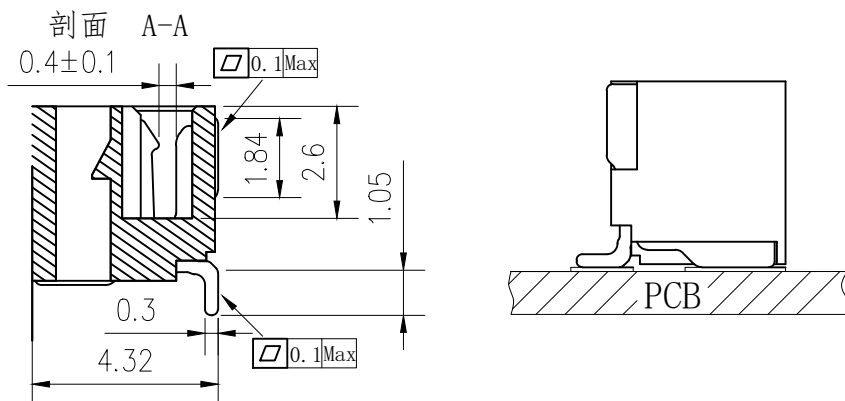

2	插针	铜	镀锡	
1	基座	LCP	本色	
序号	品名	材质	电镀/颜色	备注

深圳市虹成电子有限公司
 品名 TITLE: 针座
 料号 PART NO: HCZZ0014-7
 比例 SCALE: 1:1
 单位 UNIT: MM
 张数 PART NO: 1 OF 1
 版本 REV: A
 制图 DRAW: AhYe
 审核 CHECKED: 夏操云
 批准 APPROVE: 赵亮亮

